



US010547017B2

(12) **United States Patent**
Kim et al.

(10) **Patent No.:** **US 10,547,017 B2**
(45) **Date of Patent:** **Jan. 28, 2020**

- (54) **ORGANIC LIGHT EMITTING DIODE DISPLAY DEVICE AND METHOD OF FABRICATING THE SAME**
- (71) Applicant: **LG Display Co., Ltd.**, Seoul (KR)
- (72) Inventors: **Young-Mi Kim**, Incheon (KR);
Jong-Geun Yoon, Gyeonggi-Do (KR);
Joon-Young Heo, Seoul (KR);
Han-Sun Park, Gyeonggi-Do (KR);
Eui-Doo Do, Gyeonggi-Do (KR);
Yeon-Kyeong Lee, Gyeonggi-Do (KR);
Dae-Hyun Kim, Seoul (KR); **Jong-Sik Shim**, Seoul (KR)
- (73) Assignee: **LG Display Co., Ltd.**, Seoul (KR)
- (*) Notice: Subject to any disclaimer, the term of this patent is extended or adjusted under 35 U.S.C. 154(b) by 0 days.
- (21) Appl. No.: **16/287,312**
- (22) Filed: **Feb. 27, 2019**
- (65) **Prior Publication Data**
US 2019/0198792 A1 Jun. 27, 2019

Related U.S. Application Data

- (60) Continuation of application No. 15/948,615, filed on Apr. 9, 2018, now Pat. No. 10,256,428, which is a (Continued)

Foreign Application Priority Data

- Sep. 22, 2011 (KR) 10-2011-0095959
- Sep. 12, 2012 (KR) 10-2012-0101196

- (51) **Int. Cl.**
H01L 51/50 (2006.01)
H01L 27/32 (2006.01)
(Continued)

- (52) **U.S. Cl.**
CPC **H01L 51/5012** (2013.01); **H01L 27/3211** (2013.01); **H01L 27/3218** (2013.01);
(Continued)

- (58) **Field of Classification Search**
CPC H01L 51/0016; H01L 27/3211; H01L 51/3234; H01L 51/5092; H01L 27/3218;
(Continued)

- (56) **References Cited**
U.S. PATENT DOCUMENTS
5,294,869 A 3/1994 Tang et al.
5,294,870 A 3/1994 Tang et al.
(Continued)

FOREIGN PATENT DOCUMENTS

- CN 1328704 A 12/2001
- CN 1468041 A 1/2004
(Continued)

OTHER PUBLICATIONS

- Chinese Office Action issued in Chinese Patent Application No. 201210357124.6 dated Jan. 7, 2015.
(Continued)

Primary Examiner — Think T Nguyen
(74) *Attorney, Agent, or Firm* — Morgan, Lewis & Bockius LLP

- (57) **ABSTRACT**
In an organic light emitting diode (OLED) display device and a method for fabricating the same, OLED pixels are patterned through a photolithography process, so a large area patterning can be performed and a fine pitch can be obtained, and an organic compound layer can be protected by forming a buffer layer of a metal oxide on an upper portion of the organic compound layer or patterning the organic compound layer by using a cathode as a mask, improving device efficiency. In addition, among red, green, and blue pixels, two pixels are patterned through a lift-off process and the (Continued)

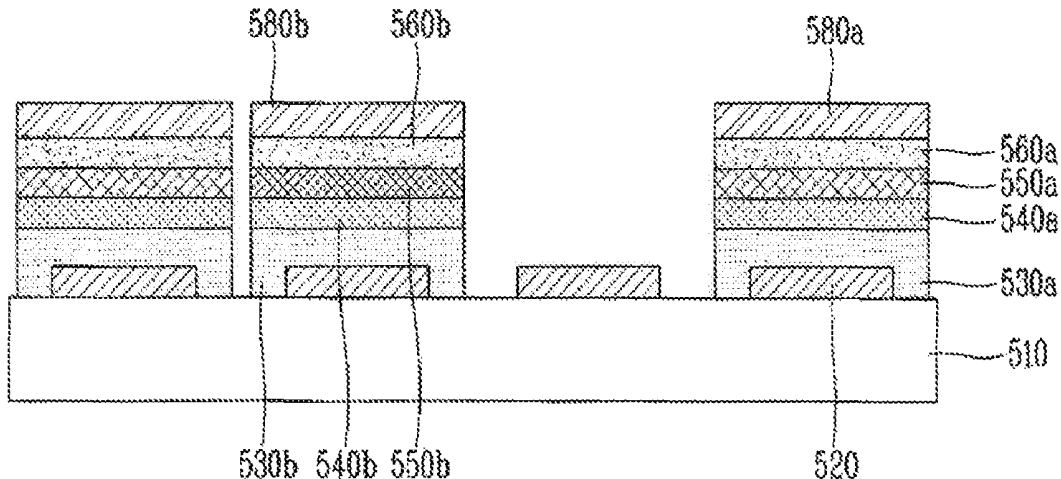

other remaining one is deposited to be formed without patterning, the process can be simplified and efficiency can be increased.

6 Claims, 20 Drawing Sheets

Related U.S. Application Data

division of application No. 15/215,339, filed on Jul. 20, 2016, now Pat. No. 9,960,376, which is a division of application No. 14/644,901, filed on Mar. 11, 2015, now Pat. No. 9,425,438, which is a division of application No. 13/624,166, filed on Sep. 21, 2012, now Pat. No. 9,006,009.

- (51) **Int. Cl.**
H01L 51/00 (2006.01)
H01L 51/52 (2006.01)
H01L 51/56 (2006.01)
H01L 27/15 (2006.01)
H01L 33/62 (2010.01)
H01L 33/20 (2010.01)
- (52) **U.S. Cl.**
 CPC *H01L 51/0002* (2013.01); *H01L 51/0016* (2013.01); *H01L 51/0018* (2013.01); *H01L 51/5056* (2013.01); *H01L 51/5072* (2013.01); *H01L 51/5088* (2013.01); *H01L 51/5092* (2013.01); *H01L 51/5234* (2013.01); *H01L 51/56* (2013.01); *H01L 27/153* (2013.01); *H01L 33/20* (2013.01); *H01L 33/62* (2013.01)
- (58) **Field of Classification Search**
 CPC H01L 51/5088; H01L 51/5002; H01L 51/5018; H01L 33/22
 USPC 438/34, 35, 42, 99; 257/40, 72, 88
 See application file for complete search history.

(56)

References Cited

U.S. PATENT DOCUMENTS

5,693,962	A	12/1997	Shi et al.
5,953,585	A	9/1999	Miyaguchi
6,120,338	A	9/2000	Hirano et al.
7,147,992	B2	12/2006	Itou et al.
7,534,557	B2	5/2009	Tachikawa et al.
7,947,518	B2	5/2011	Tsai
8,471,275	B2	6/2013	Lee et al.
8,664,017	B2	3/2014	Fushimi et al.
2002/0072139	A1	6/2002	Kashiwabara
2003/0160564	A1	8/2003	Park et al.
2005/0153058	A1	7/2005	Tachikawa et al.
2007/0114909	A1	5/2007	Park et al.
2008/0124824	A1	5/2008	Tsai et al.
2008/0129191	A1	6/2008	Lee et al.
2010/0140645	A1*	6/2010	Shibata et al. H01L 51/5016 257/40

FOREIGN PATENT DOCUMENTS

CN	1653855	A	8/2005
CN	101257744	A	9/2008
CN	102169959	A	8/2011
JP	2002-0359074	A	12/2002
JP	2008-085200	A	4/2008
JP	2008-147072	A	6/2008
TW	200826330	A	6/2008
WO	2008-038588	A1	4/2008

OTHER PUBLICATIONS

KIPO: Office Action for Korean Patent Application No. KR 10-2012-0101196 dated Apr. 19, 2014.
 Extended European Search Report issued in corresponding European Patent Application No. 12006623.8 dated Mar. 11, 2013.
 English Translation of Japanese PCT WO 2008/03588 A1 (Apr. 2008) Naotoshi et al.

* cited by examiner

FIG. 1
RELATED ART

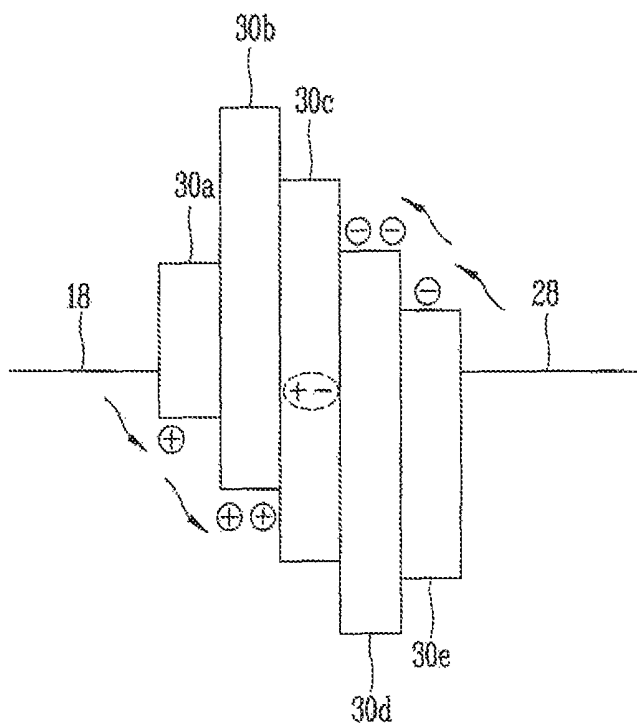

FIG. 2
RELATED ART

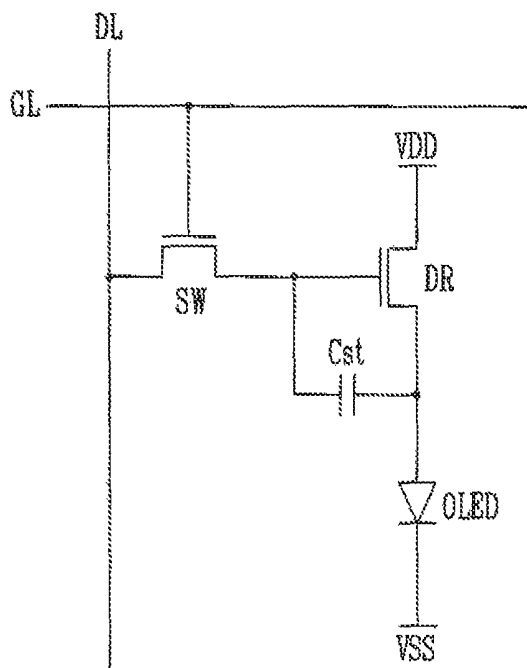

FIG. 3A

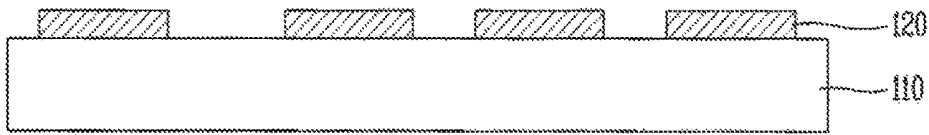

FIG. 3B

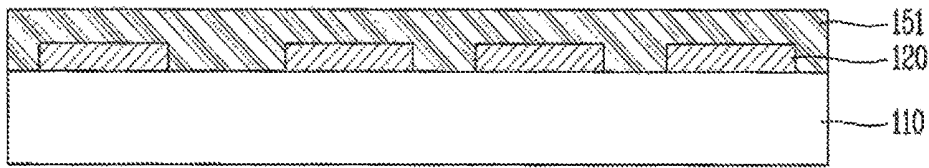

FIG. 3C

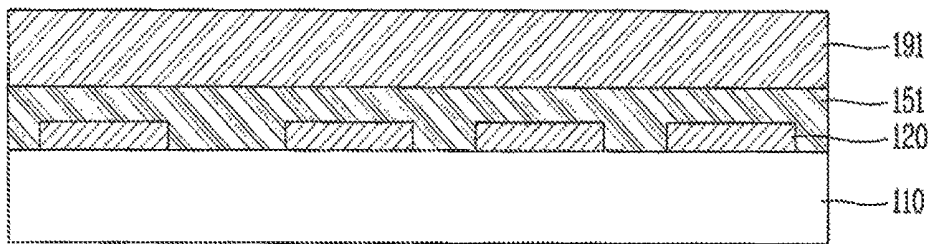

FIG. 3D

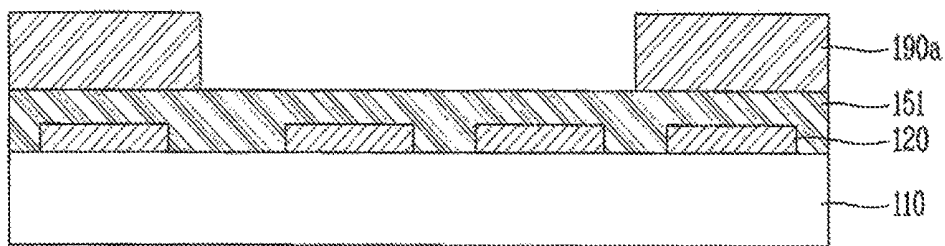

FIG. 3E

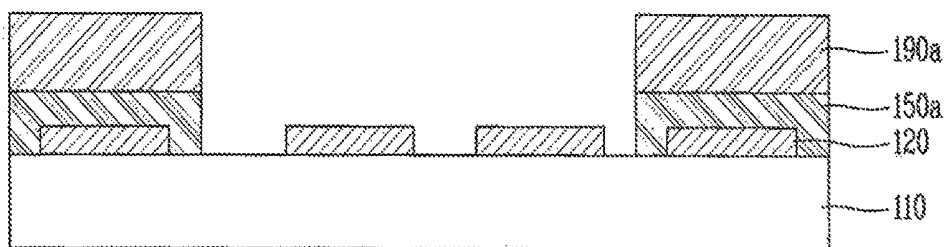

FIG. 3F

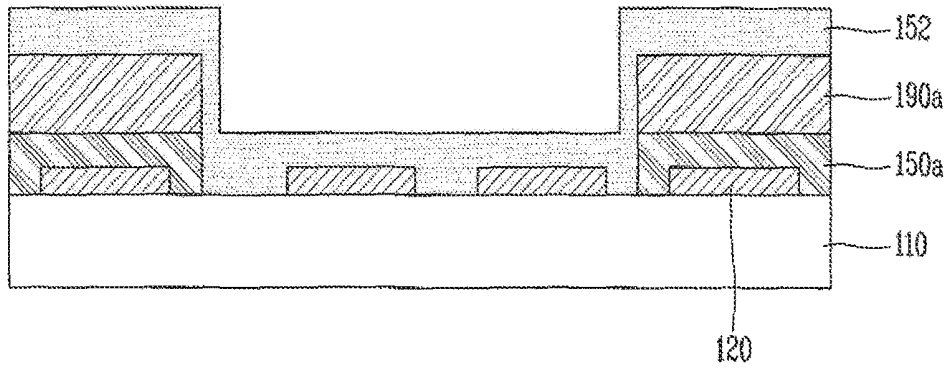

FIG. 3G

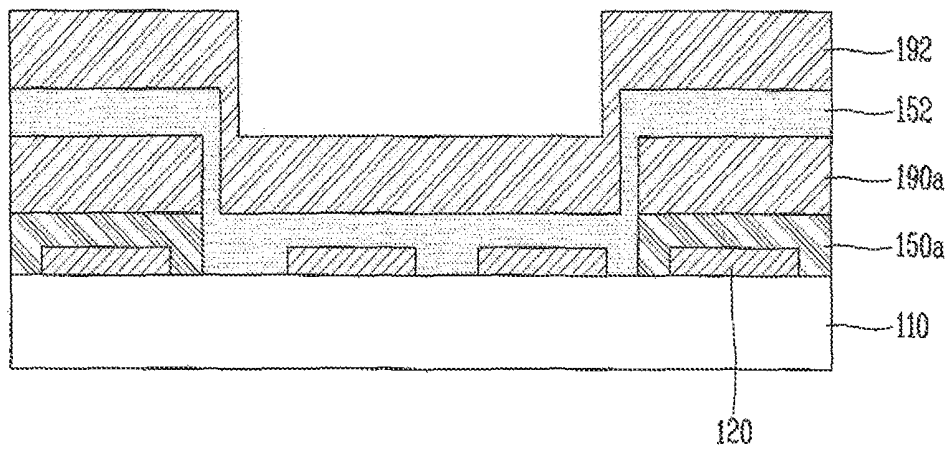

FIG. 3H

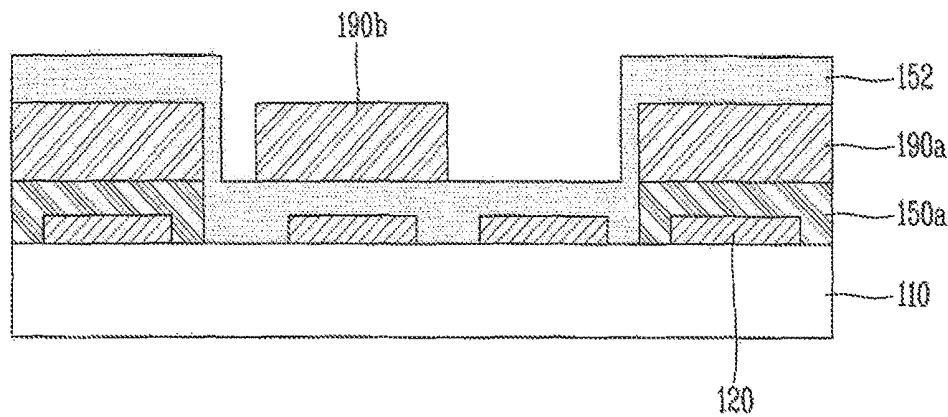

FIG. 3I

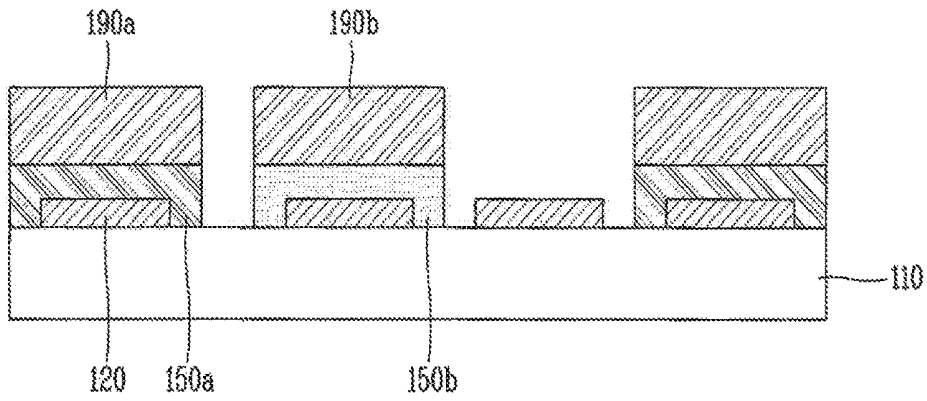

FIG. 3J

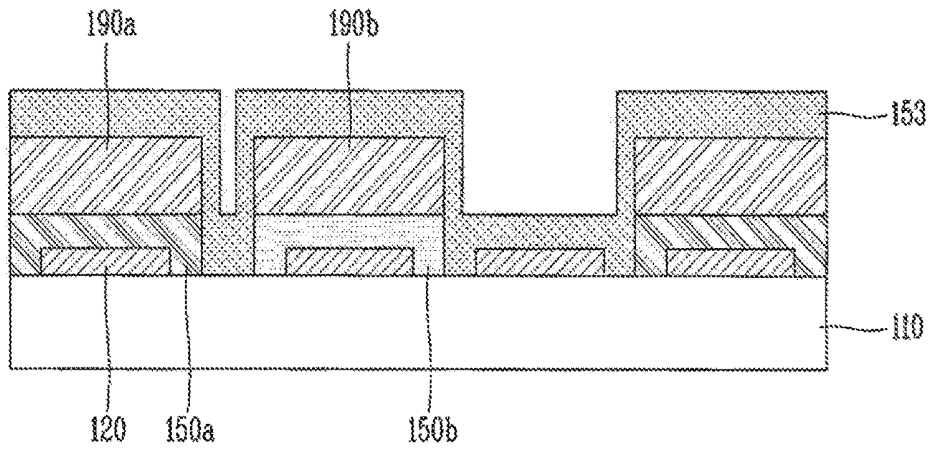

FIG. 3K

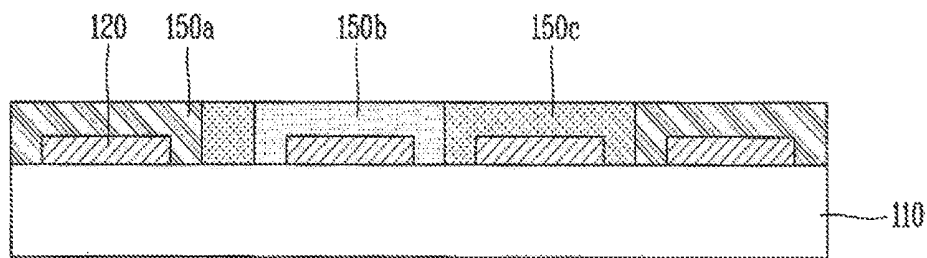

FIG. 3L

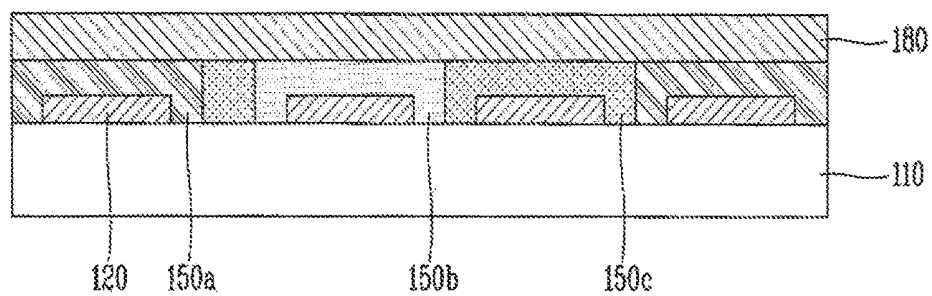

FIG. 4A

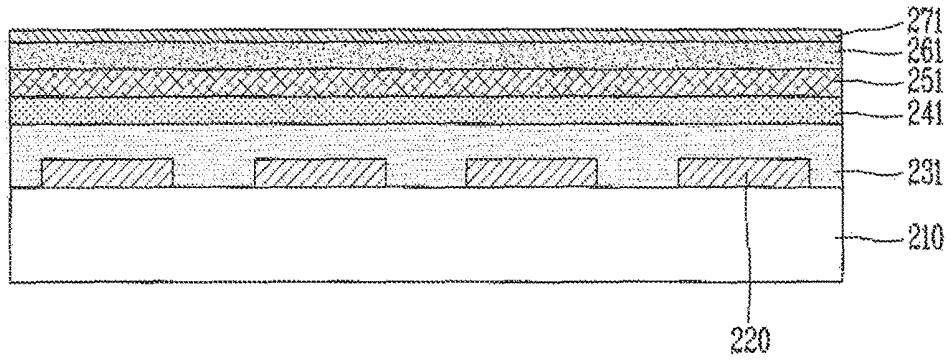

FIG. 4B

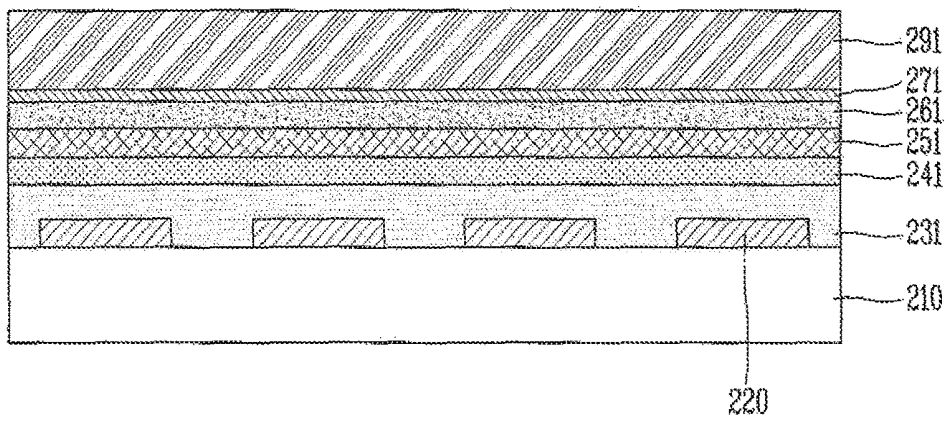

FIG. 4C

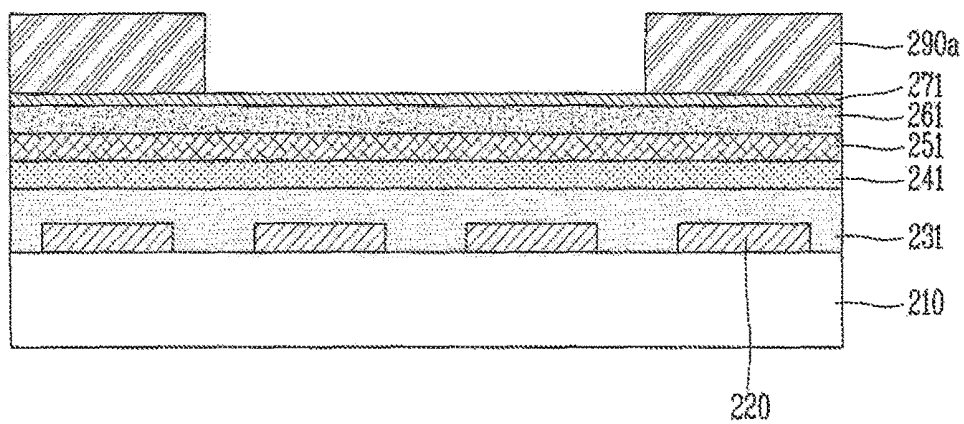

FIG. 4D

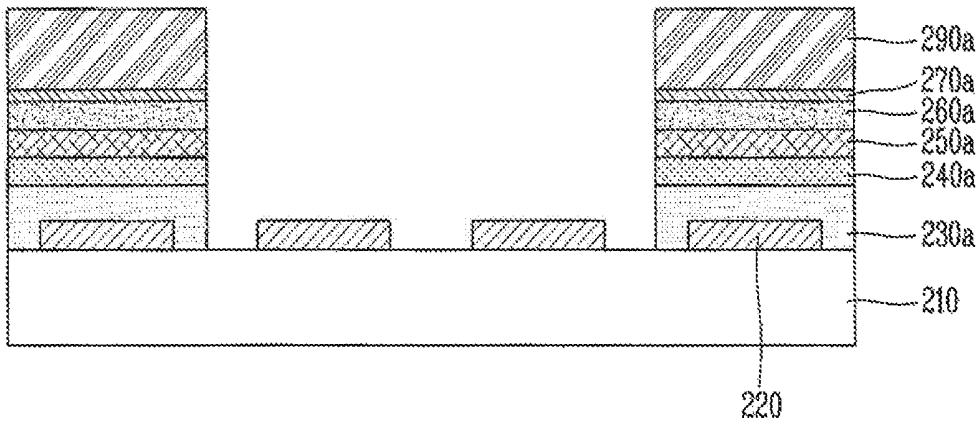

FIG. 4E

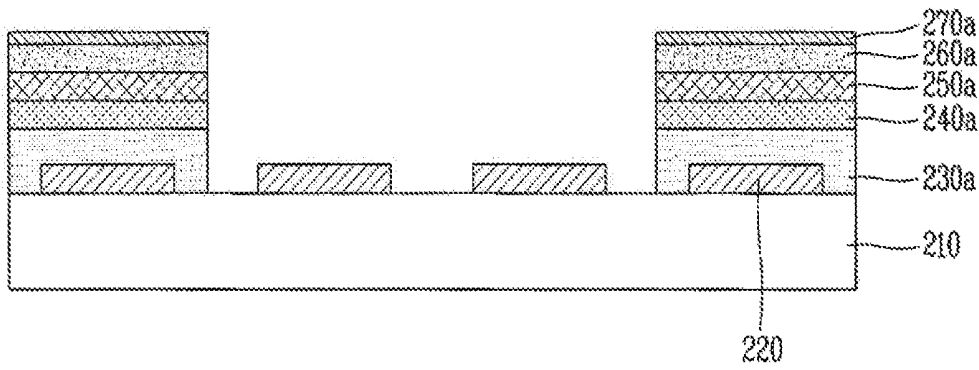

FIG. 4F

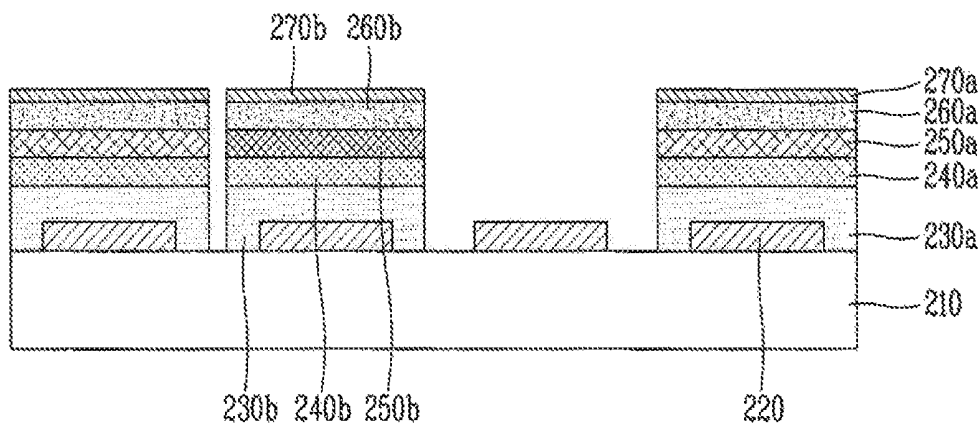

FIG. 4G

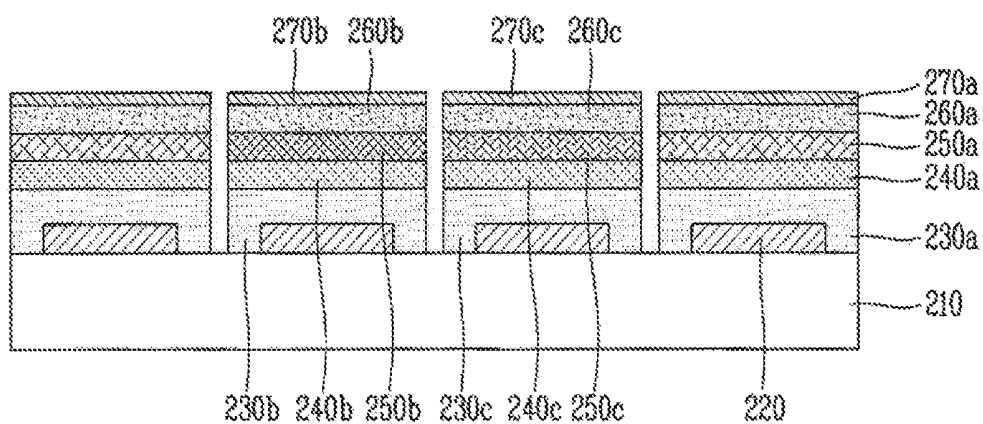

FIG. 4H

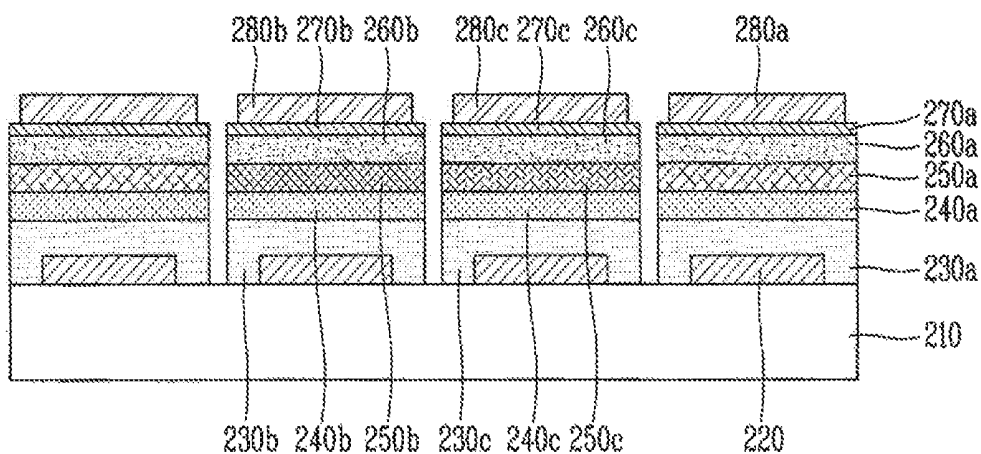

FIG. 5A

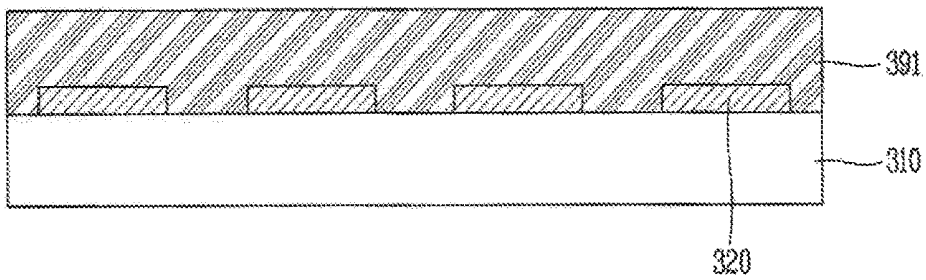

FIG. 5B

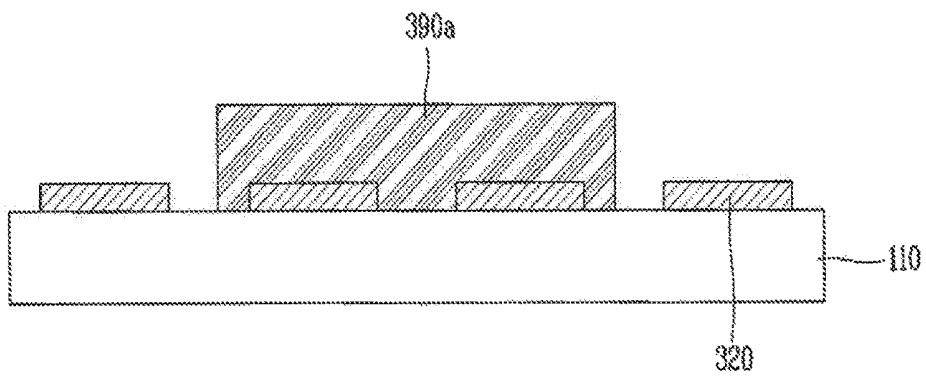

FIG. 5C

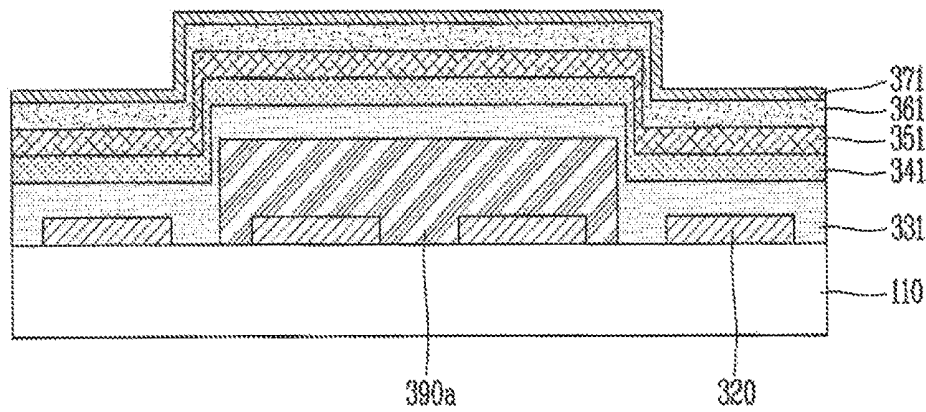

FIG. 5D

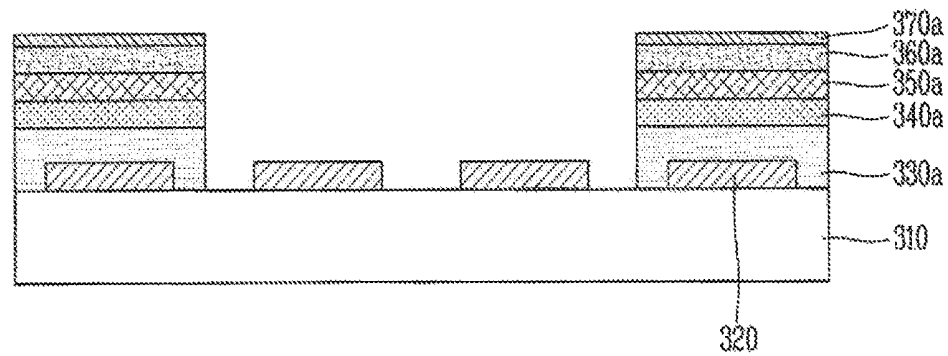

FIG. 5E

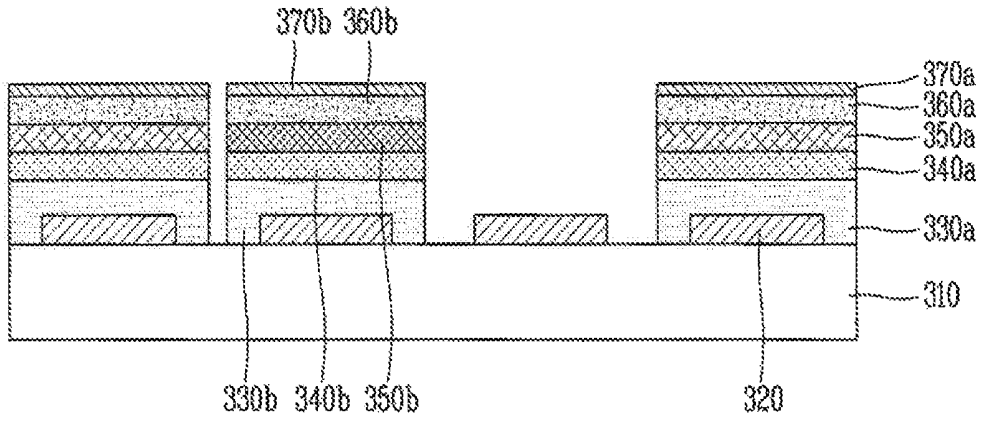

FIG. 5F

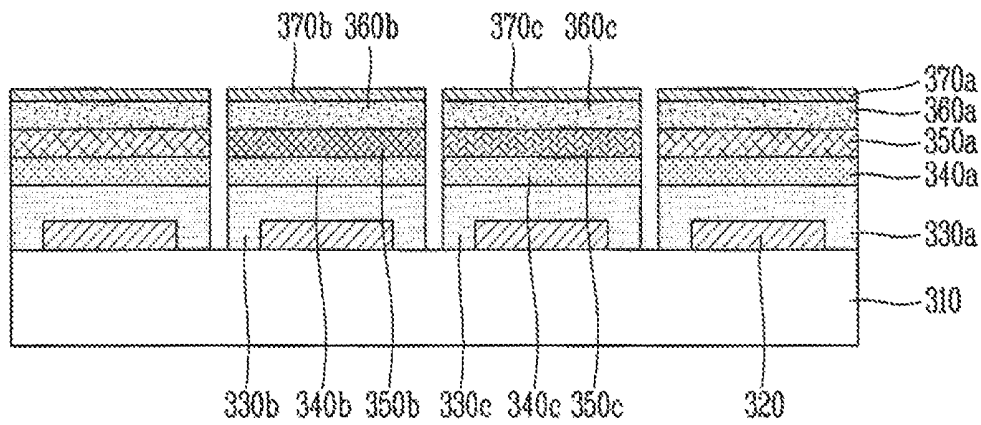

FIG. 5G

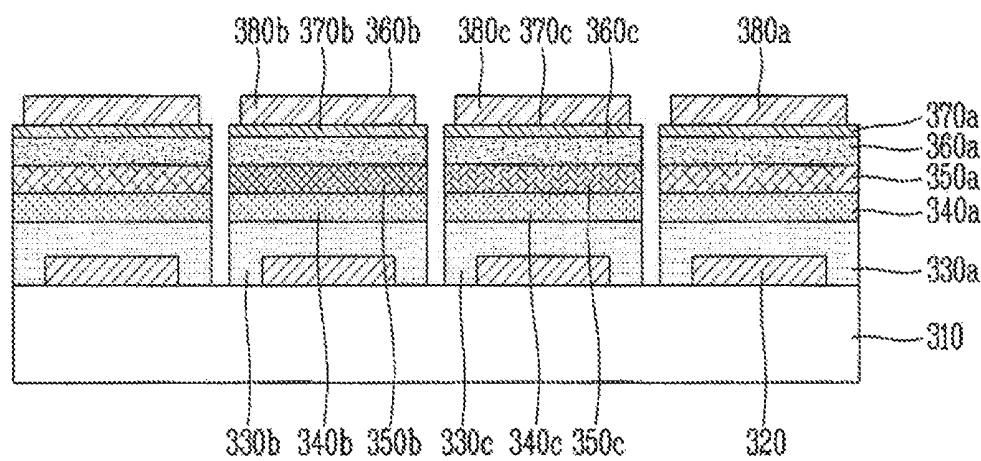

FIG. 6

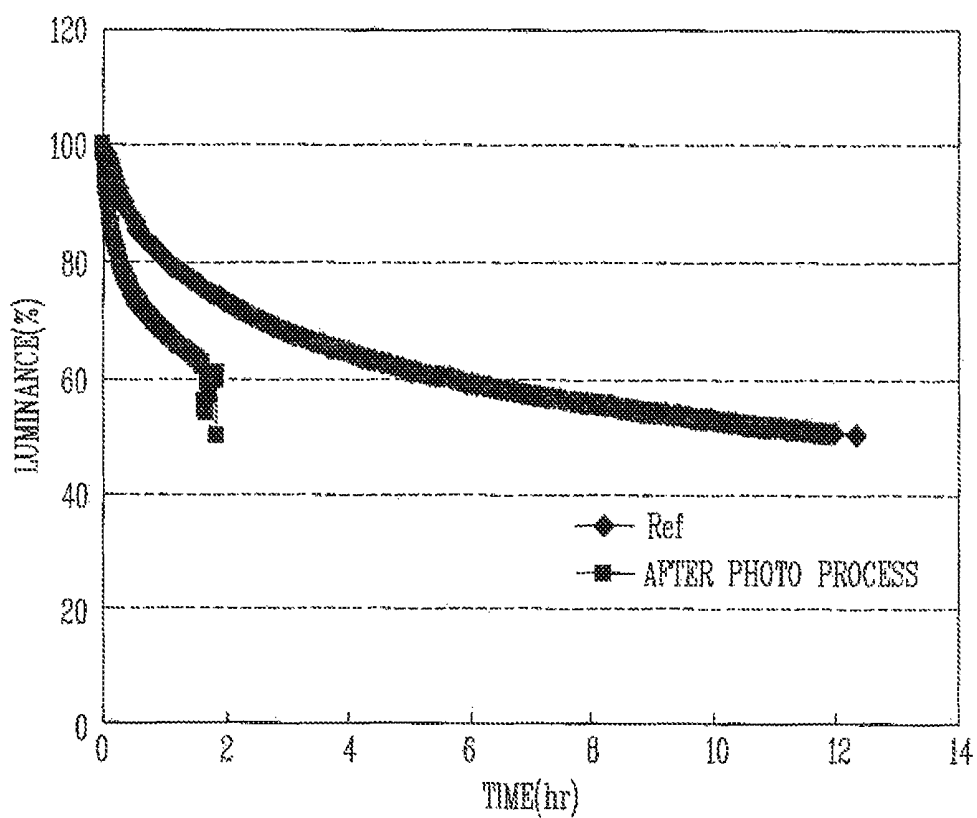

FIG. 7A

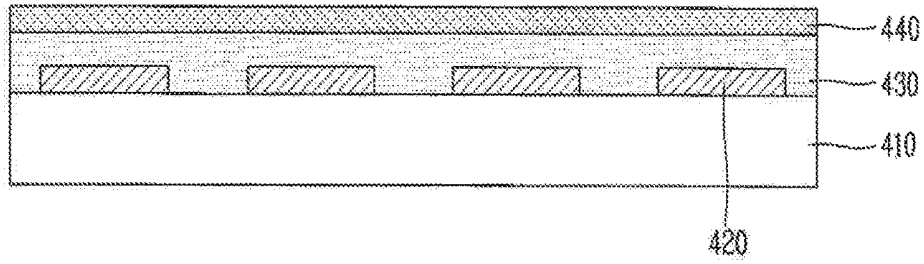

FIG. 7B

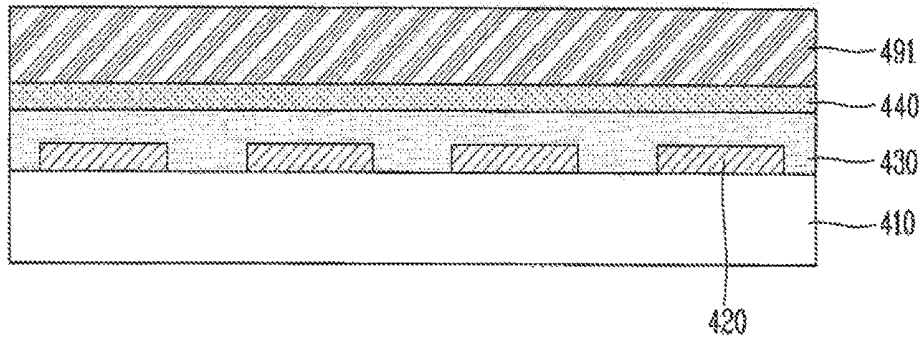

FIG. 7C

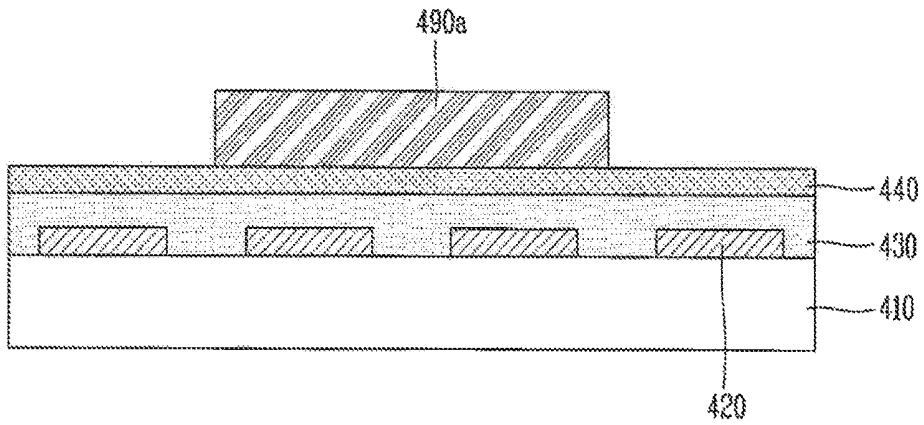

FIG. 7D

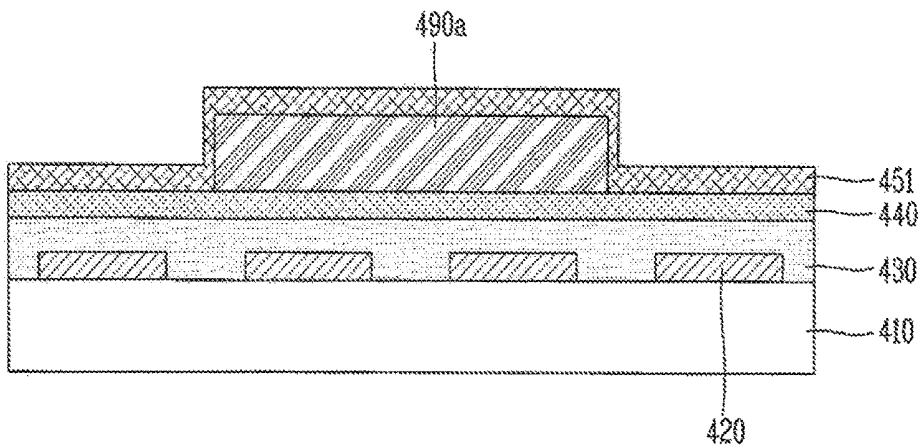

FIG. 7E

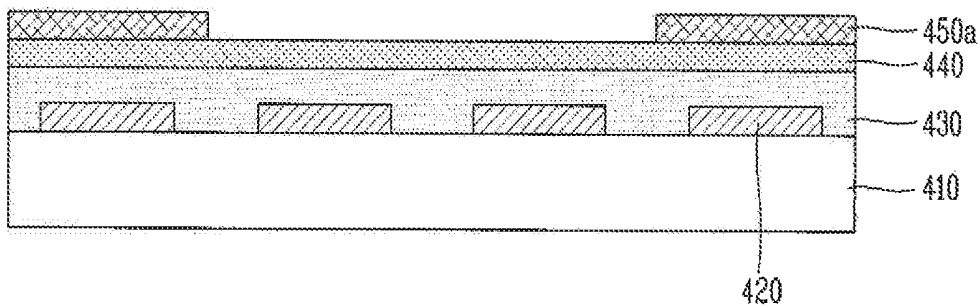

FIG. 7F

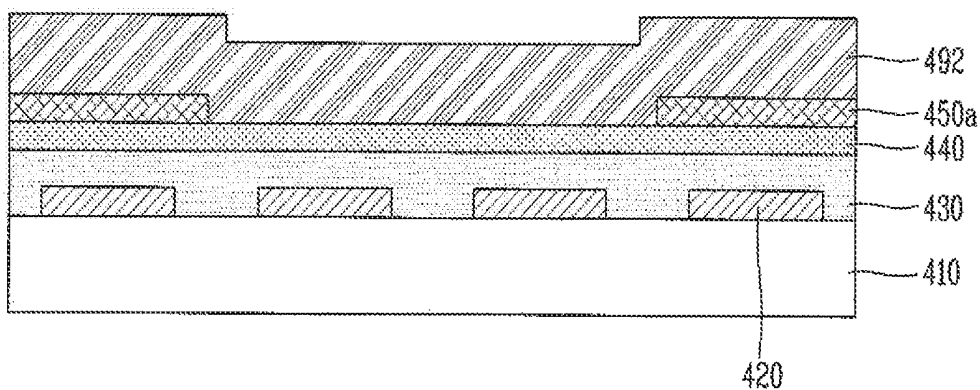

FIG. 7G

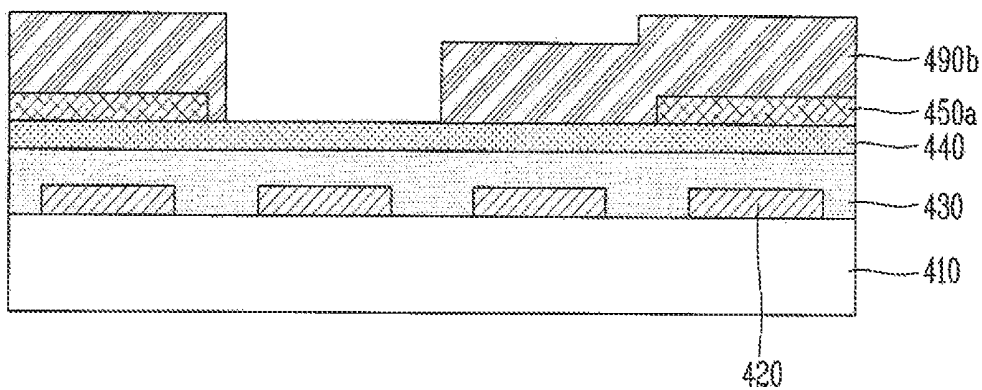

FIG. 7H

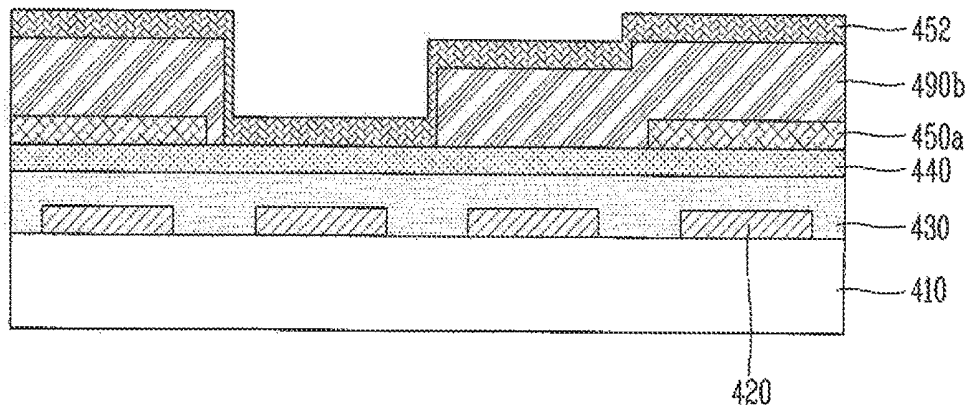

FIG. 7I

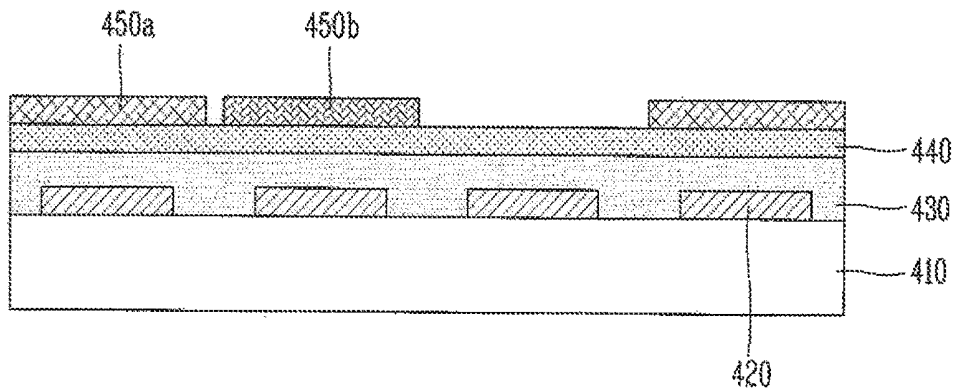

FIG. 7J

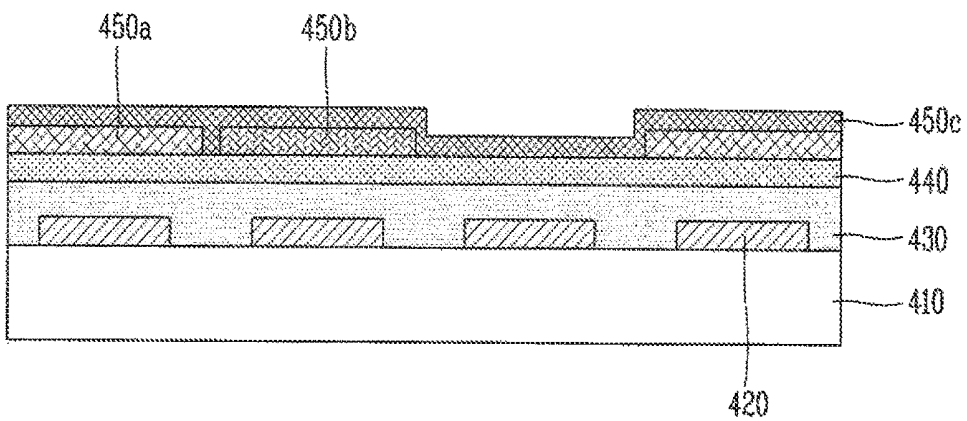

FIG. 7K

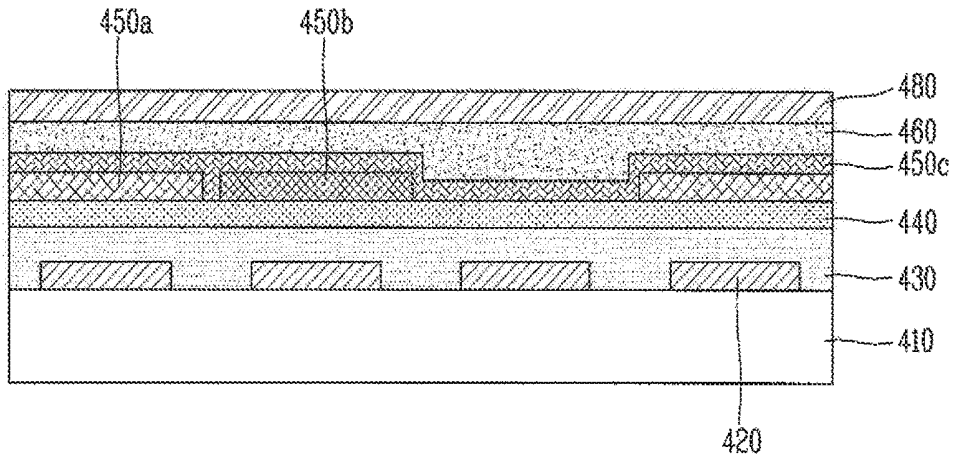

FIG. 8

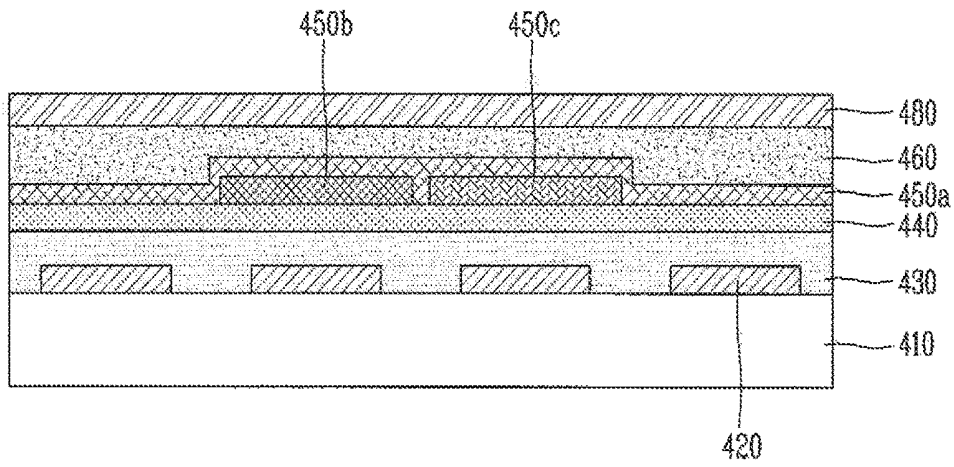

FIG. 9

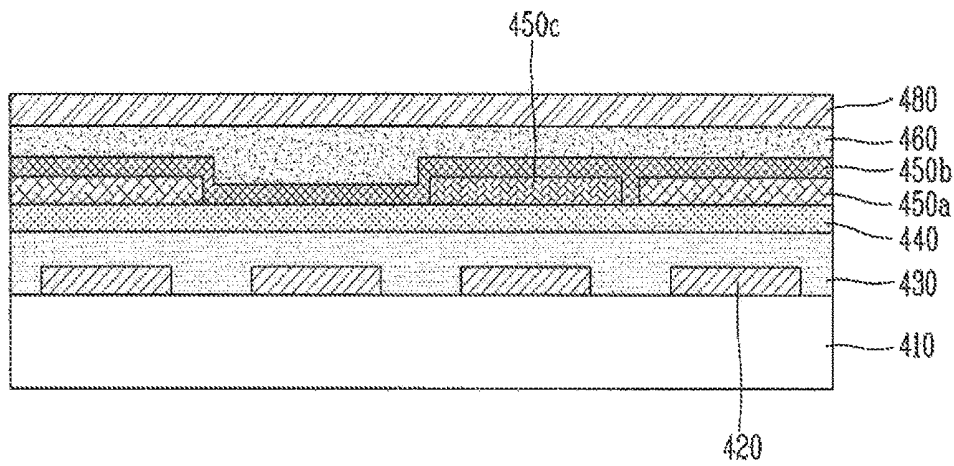

FIG. 10A

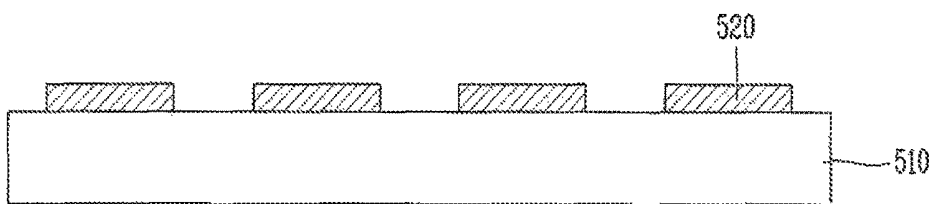

FIG. 10B

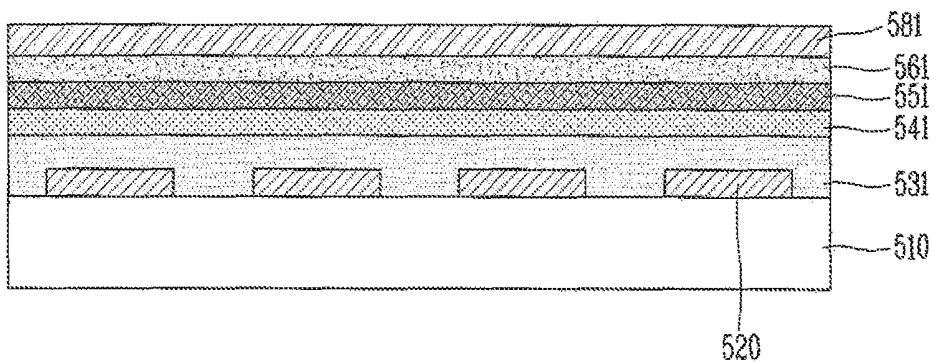

FIG. 10C

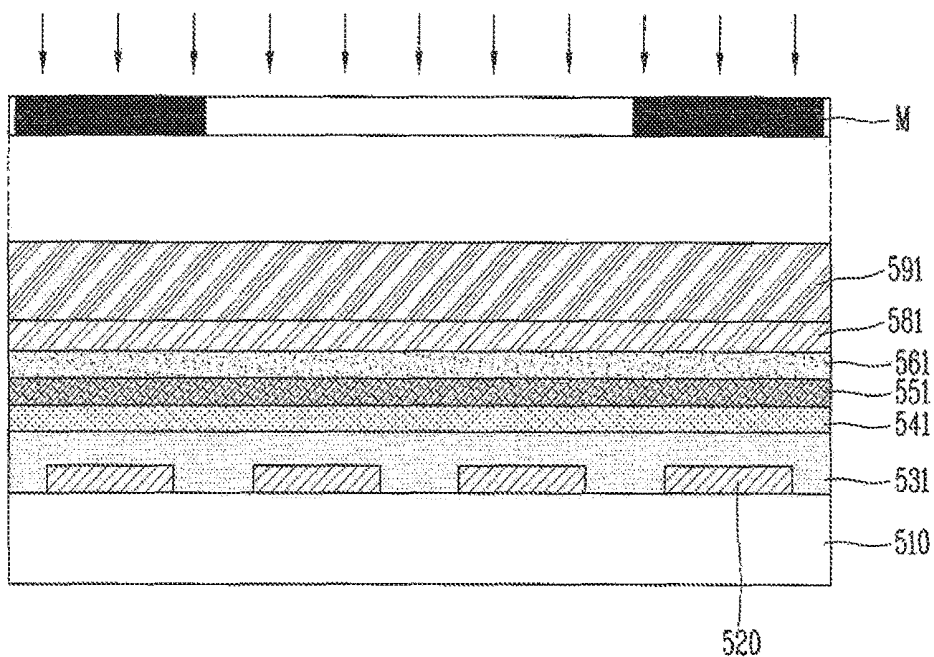

FIG. 10D

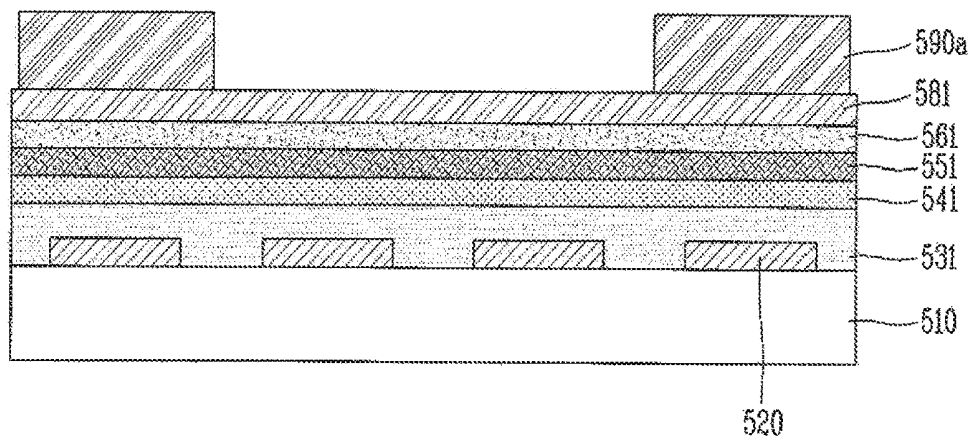

FIG. 10E

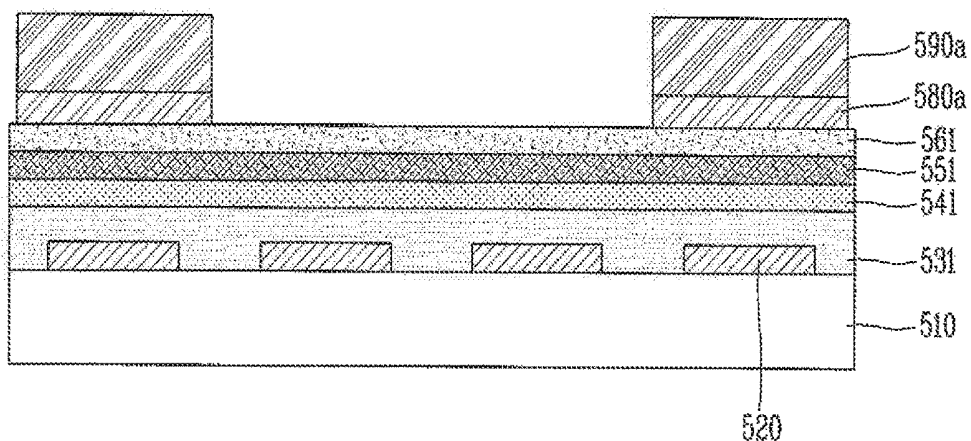

FIG. 10F

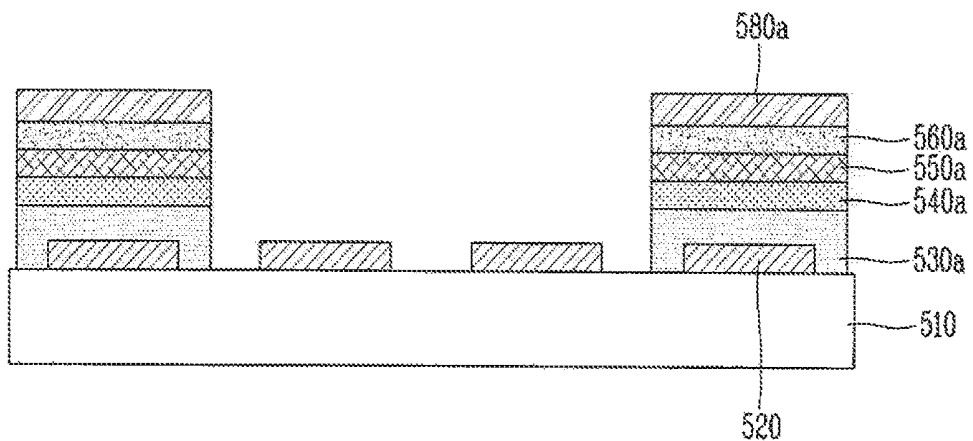

FIG. 10G

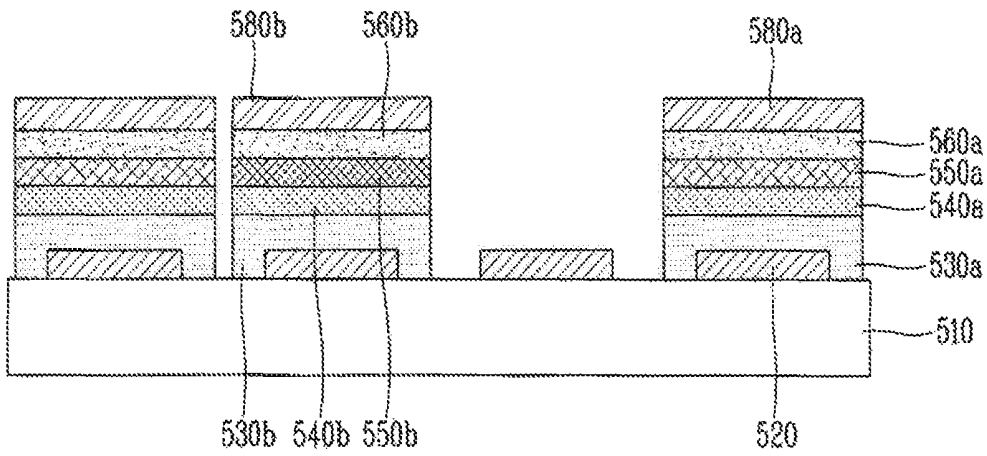

FIG. 10H

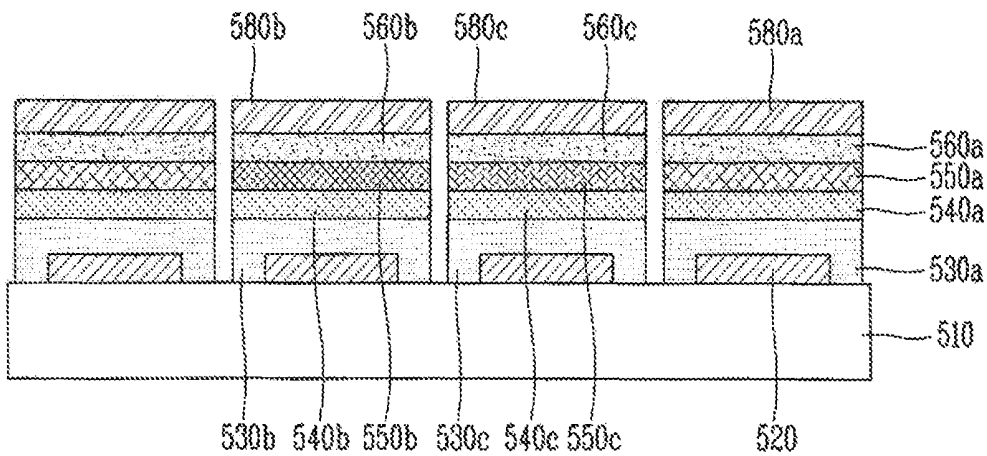

FIG. 11A

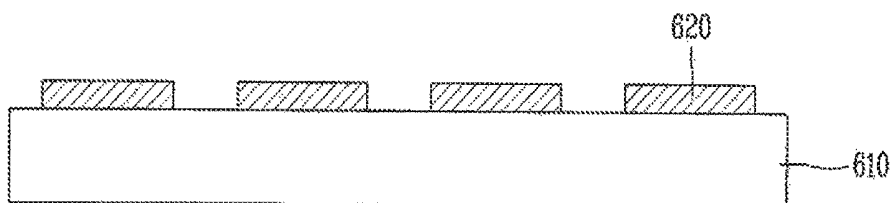

FIG. 11B

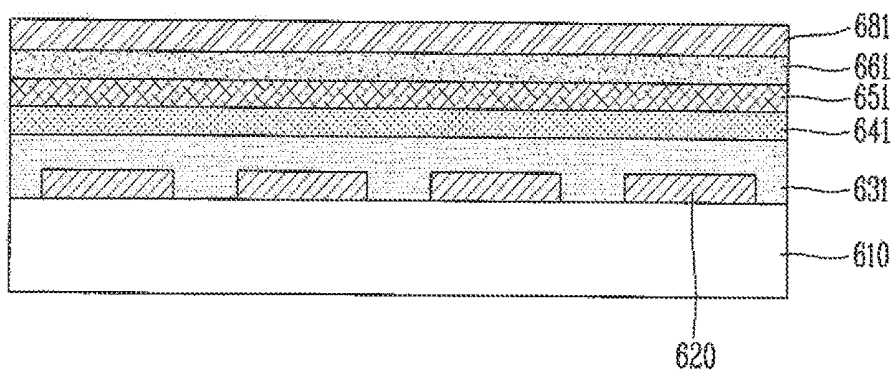

FIG. 11C

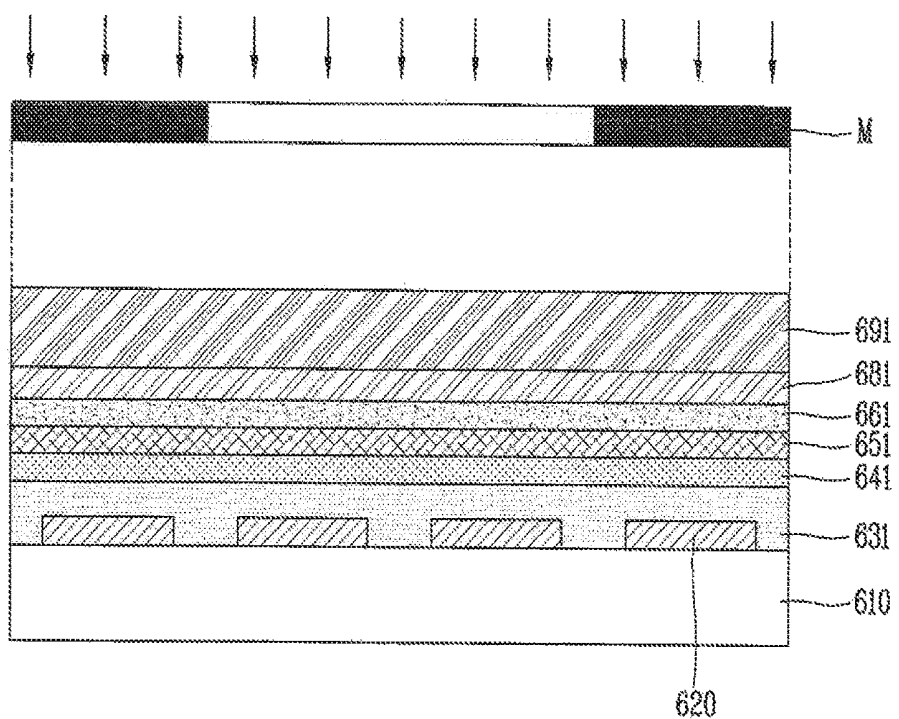

FIG. 11D

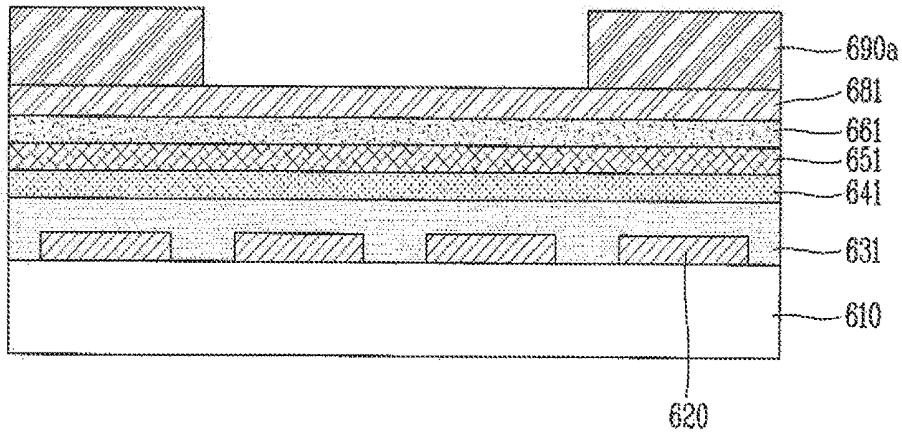

FIG. 11E

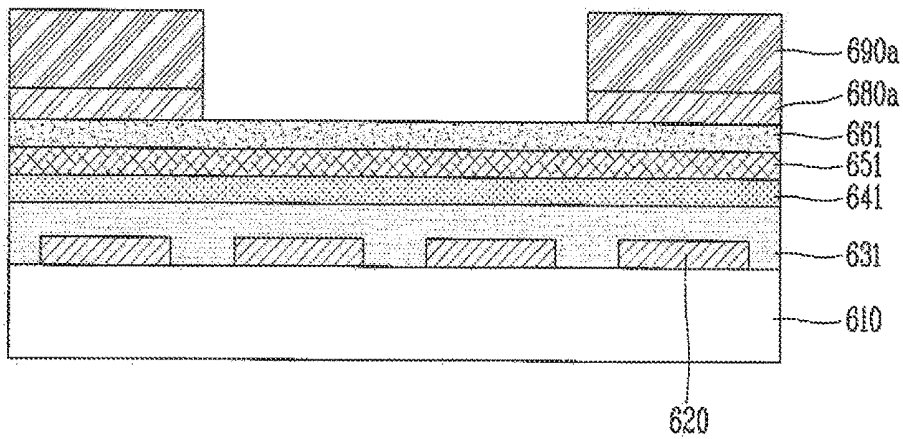

FIG. 11F

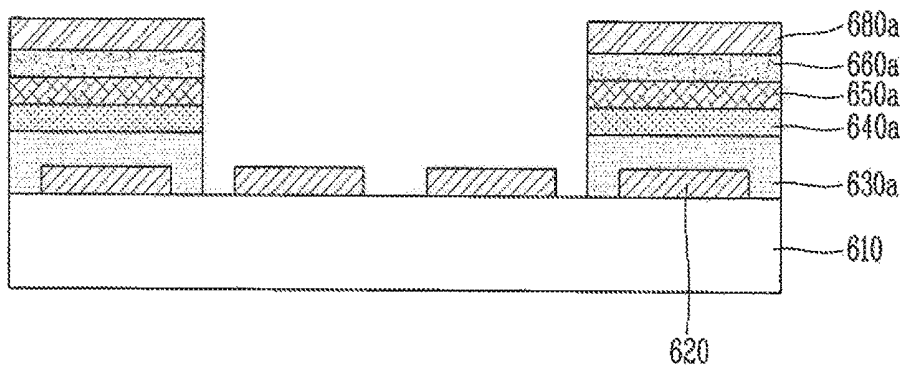

FIG. 11G

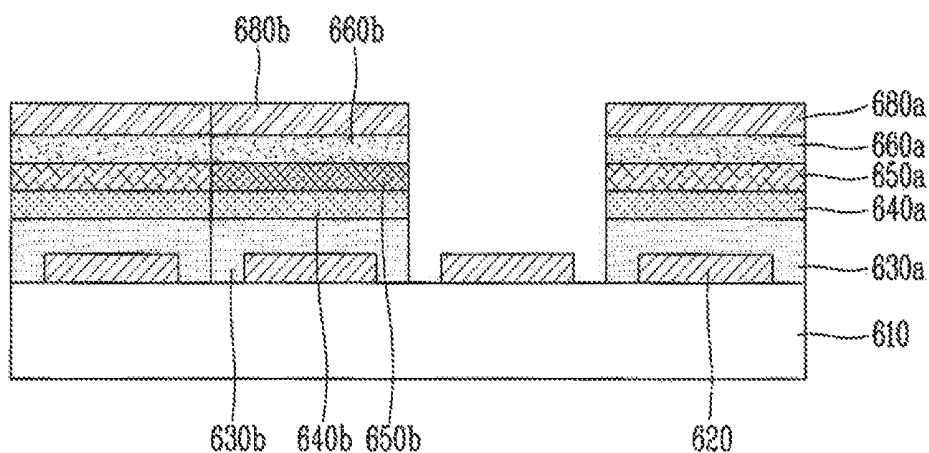
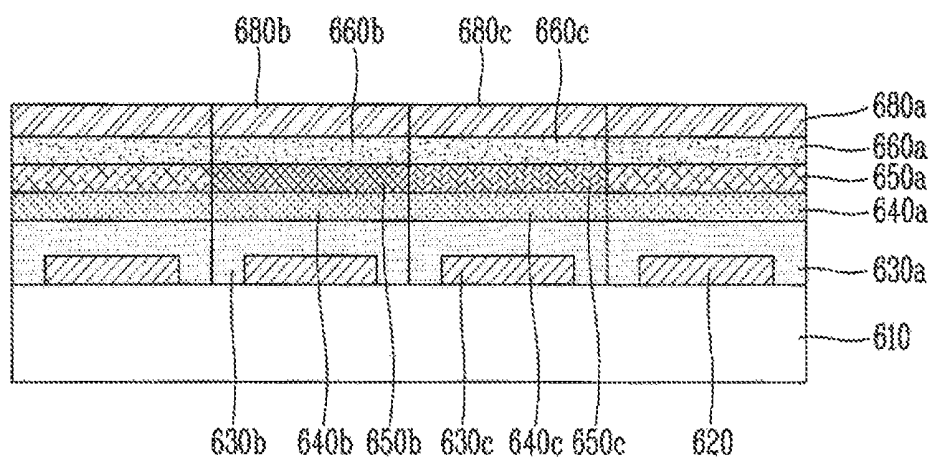

FIG. 11H



**ORGANIC LIGHT EMITTING DIODE
DISPLAY DEVICE AND METHOD OF
FABRICATING THE SAME**

CROSS REFERENCE TO RELATED
APPLICATION

This application is a continuation of U.S. patent application Ser. No. 15/948,615, filed Apr. 9, 2018, which is a divisional of U.S. patent application Ser. No. 15/215,339, filed on Jul. 20, 2016 (now U.S. Pat. No. 9,960,376, issued on May 1, 2018), which is a divisional of U.S. patent application Ser. No. 14/644,901, filed on Mar. 11, 2015 (now U.S. Pat. No. 9,425,438, issued on Aug. 23, 2016), which is a divisional of U.S. patent application Ser. No. 13/624,166, filed on Sep. 21, 2012 (now U.S. Pat. No. 9,006,009, issued on Apr. 14, 2015), which claims the benefit of Korean Applications No. 10-2011-0095959, filed on Sep. 22, 2011, and No. 10-2012-0101196, filed on Sep. 12, 2012, all of which are hereby expressly incorporated by reference in their entireties.

FIELD OF THE INVENTION

The present invention relates to organic light emitting diode (OLED) display device and a method of fabricating the same and, more particularly, to an OLED display device in which OLED pixels are patterned through a photolithography process, and a method of fabricating the same.

DESCRIPTION OF THE RELATED ART

Recently, as interest in information displays has been on the rise and demand for the use of portable information media has been increased, lightweight flat panel displays (FPDs) substituting cathode ray tubes (CRTs) as existing display devices have been actively researched and commercialized.

In the FPD fields, a liquid crystal display (LCD) device, which is lighter and consumes less power, has been spotlighted; however, since an LCD device is a light receiving device, rather than a light emitting device, having shortcomings of brightness, contrast ratio, and a viewing angle, and the like, so a development of a new display device that may overcome such drawbacks has been actively made.

An LED display device, one of new display devices, is a self-luminous type device, which thus is excellent in a viewing angle and contrast ratio, is lighter and thinner because it does not need a backlight, and is advantageous in terms of power consumption, relative to an LCD device. In addition, an OLED display device can be driven by a DC and at a low voltage, has a fast response speed, and is especially advantageous in terms of fabrication costs.

Unlike an LCD device or a plasma display panel (PDP), deposition and encapsulation are the whole of a fabrication process of an OLED display device, so the fabrication process is very simple. Also, when the OLED display device is driven according to an active matrix scheme in which each pixel has a thin film transistor (TFT) as a switching element, the same luminance can be obtained although a low current is applied, so, advantageously, the OLED display device consumes low power, has a high pitch (or high definition or high resolution), and can be increased in size.

Hereinafter, a basic structure and operational characteristics of an OLED display device will be described in detail with reference to the accompanying drawings.

FIG. 1 is a diagram illustrating a light emission principle of a general OLED display device.

As shown in FIG. 1, a general OLED display device includes an OLED. The OLED includes organic compound layers **301**, **30b**, **30c**, **30d**, and **30e** formed between an anode **18** as a pixel electrode and a cathode **28** as a common electrode.

Here, the organic compound layers **30a**, **30b**, **30c**, **30d**, and **30e** include a hole injection layer **30a**, a hole transport layer **30b**, an emission layer **30c**, an electron transport layer **30d**, and an electron injection layer **30e**.

When a driving voltage is applied to the anode **18** and the cathode **28**, holes which have passed through the hole transport layer **30b** and electrons which have passed through the electron transport layer **30e** move to the light emission layer **30c** to form excitons, and as a result, the light emission layer **30c** emits visible light.

In the OLED display device, the pixels each having the OLED having the foregoing structure are arranged in a matrix form and selectively controlled by a data voltage and a scan voltage to display an image.

The OLED display device is divided into a passive matrix type OLED display device and an active matrix type display device using TFTs as switching elements. Among them, in the active matrix type OLED display device, TFTs as active elements are selectively turned on to select pixels and emitting of pixels is maintained by a voltage maintained in a storage capacitor.

FIG. 2 is an equivalent circuit diagram of a pixel in a general OLED display device. Namely, FIG. 2 illustrates an example of an equivalent circuit diagram of a pixel having a general 2T1C (including two transistors and one capacitor) in an active matrix type OLED display device.

Referring to FIG. 2, a pixel of an active matrix type OLED display device includes an OLED, a data line DL and a gate line GL crossing each other, a switching TFT SW, a driving TFT DR, and a storage capacitor Cst.

Here, the switching TFT SW is turned on in response to a scan pulse from the gate line GL to conduct a current path between a source electrode and a drain electrode thereof. During an ON-time period of the switching TFT SW, a data voltage from the data line DL is applied to a gate electrode of the driving TFT DR and the storage capacitor Cst by way of the source electrode and drain electrode of the switching TFT SW.

Here, the driving TFT DR controls a current flowing in the OLED according to the data voltage applied to the gate electrode thereof. The storage capacitor Cst stores a voltage between the data voltage and a low potential power source voltage VSS and uniformly maintains it during one frame period.

In order to form the several organic compound layers constituting the OLED display device, a vacuum evaporation method is largely used.

Here, in order to use the vacuum evaporation method, a mask (or a shadow mask) or a fine metal mask (FMM) having a plurality of openings corresponding to a plurality of pixel regions is used. However, this method has a limitation in that it is not easy to cope with a fine pitch of patterns for increasing a size of a substrate and implementing a high resolution display

Namely, FMM is fabricated by forming holes as a pattern intended for deposition on a thin metal plate and stretching the same. Thus, there is a limitation in forming a pattern having a small size, making it difficult to reduce the size of an OLED. Also, when a fine metal mask is increased in size in order to increase a size of a panel, warpage occurs due to

the characteristics of the fine metal mask, distort the pattern to degrade a production yield.

SUMMARY OF THE INVENTION

An aspect of the present invention provides an organic light emitting diode (OLED) display device in which OLED pixels are patterned through a photolithography process, thus being available for large area patterning and obtaining a high pitch (or high definition or high resolution), and a method for fabricating the same.

Another aspect of the present invention provides an OLED display device in which a light emitting layer is protected during a patterning process through photolithography, and a method for fabricating the same.

Another aspect of the present invention provides an OLED display device capable of simplifying a process and increasing efficiency, and a method for fabricating the same.

According to an aspect of the present invention, there is provided an organic light emitting diode (OLED) display device including: a first electrode formed on a substrate; a hole injection layer and a hole transport layer formed on the substrate with the first electrode formed thereon; a first light emitting layer formed of a first organic film on the substrate with the hole injection layer and the hole transport layer formed thereon; a second light emitting layer formed of a second organic film on the substrate with the first light emitting layer formed thereon; a third light emitting layer formed by depositing a third organic film on the entire surface of the substrate with the first light emitting layer and the second light emitting layer formed thereon; and an electron injection layer and a second electrode formed on the third light emitting layer.

The third light emitting layer may be formed on upper portions of the first light emitting layer and the second light emitting layer as well as between the first light emitting layer and the second light emitting layer.

According to another aspect of the present invention, there is provided an organic light emitting diode (OLED) display device including: a first electrode formed on a substrate; a first hole injection layer, a first hole transport layer, a first light emitting layer, a first electron transport layer, and a first buffer layer laminated on the substrate; a second hole injection layer, a second hole transport layer, a second light emitting layer, a second electron transport layer, and a second buffer layer laminated on the substrate; a third hole injection layer, a third hole transport layer, a third light emitting layer, a third electron transport layer, and a third buffer layer laminated on the substrate; and a second electrode formed on the first, second, and third buffer layers, wherein the first, second, and third buffer layers are made of a metal oxide.

The first, second, and third buffer layers may be made of a 1-2 Group and 12-16 Group metal oxide or 3-12 Group transition metal oxide.

According to another aspect of the present invention, there is provided a method for fabricating an organic light emitting diode (OLED) display device, including: forming a first electrode on a substrate; forming a first light emitting layer formed of a first organic film on the substrate through a first photo process; forming a second light emitting layer formed of a second organic film on the substrate through a second photo process; depositing a third organic film on first and second photosensitive resin patterns remaining after being used during the first and second photo processes; removing the third organic film deposited on upper portions of the first and second photosensitive resin patterns together

with the first and second photosensitive resin patterns through a lift-off process to form a third light emitting layer; and forming a second electrode on the first, second, and third light emitting layers.

According to another aspect of the present invention, there is provided a method for fabricating an organic light emitting diode (OLED) display device, including: (a) forming a first electrode on a substrate; (b) applying a photosensitive resin to the entire surface of the substrate to form a first photosensitive resin layer; (c) selectively exposing and developing the first photosensitive resin layer to form a first photosensitive resin pattern made of the photosensitive resin at a position other than a position where a first light emitting layer is to be formed; (d) depositing a first organic film on the first photosensitive resin pattern in a state in which the first photosensitive resin pattern remains; (e) removing the first organic film deposited on an upper portion of the first photosensitive resin pattern together with the first photosensitive resin pattern through a lift-off process to form a first light emitting layer formed of the first organic film on the substrate; (f) forming a second light emitting layer formed of a second organic film on the substrate through the same processes as (b) to (e); (g) depositing a third organic film on the entire surface of the substrate with the first light emitting layer and the second light emitting layer formed thereon; and (h) forming a second electrode on the substrate.

The third light emitting layer may be formed between the first light emitting layer and the second light emitting layer.

The third light emitting layer may be formed on upper portions of the first light emitting layer and the second light emitting layer as well as between the first light emitting layer and the second light emitting layer.

After a hole injection layer and a hole transport layer are formed on the substrate with the first electrode formed thereon, the first light emitting layer may be formed thereon.

The first light emitting layer may be formed as any one of red, green, and blue light emitting layers.

The second light emitting layer may be formed as another one of the red, green, and blue light emitting layers.

The third light emitting layer may be formed as the other remaining one of the red, green, and blue light emitting layers.

After an electron transport layer and an electron injection layer are formed on the substrate with the first, second, and third light emitting layers formed thereon, the second electrode may be formed thereon.

According to another aspect of the present invention, there is provided a method for fabricating an organic light emitting diode (OLED) display device, including: forming a first electrode on a substrate; forming a first hole injection layer, a first hole transport layer, a first light emitting layer, a first electron transport layer, and a first buffer layer in a laminated manner on the substrate through a first photo process; forming a second hole injection layer, a second hole transport layer, a second light emitting layer, a second electron transport layer, and a second buffer layer in a laminated manner on the substrate through a first photo process; forming a third hole injection layer, a third hole transport layer, a third light emitting layer, a third electron transport layer, and a third buffer layer in a laminated manner on the substrate through a first photo process; and forming a second electrode on the first, second, and third buffer layers, wherein the first, second, and third buffer layers are made of a metal oxide.

According to another aspect of the present invention, there is provided a method for fabricating an organic light emitting diode (OLED) display device, including: (a) form-

ing a first electrode on a substrate; (b) applying a photosensitive resin to the entire surface of the substrate to form a first photosensitive resin layer; (c) selectively exposing and developing the first photosensitive resin layer to form a first photosensitive resin pattern made of the photosensitive resin at a position other than a position where a first light emitting layer is to be formed; (d) depositing a thin film for a first hole injection layer, a thin film for a first hole transport layer, a first organic film, a thin film for a first electron transport layer, and a thin film for a first buffer layer in a state in which the first photosensitive resin pattern remains; (e) removing the thin film for a first hole injection layer, the thin film for a first hole transport layer, the first organic film, the thin film for a first electron transport layer, and the thin film for a first buffer layer deposited on an upper portion of the first photosensitive resin pattern together with the first photosensitive resin pattern through a lift-off process to form a first hole injection layer, a first hole transport layer, a first light emitting layer, a first electron transport layer, and a first buffer layer, which are formed of thin film for a first hole injection layer, the thin film for a first hole transport layer, the first organic film, the thin film for a first electron transport layer, and the thin film for a first buffer layer, respectively, on the substrate; (f) forming a second hole injection layer, a second hole transport layer, a second light emitting layer, a second electron transport layer, and a second buffer layer through the same processes as (b) to (e); (g) forming a third hole injection layer, a third hole transport layer, a third light emitting layer, a third electron transport layer, and a third buffer layer through the same processes as (b) to (e); and (h) forming a second electrode on the first, second, and third buffer layers, wherein the first, second, and third buffer layers are made of a metal oxide.

The forming of the first hole injection layer, the first hole transport layer, the first light emitting layer, the first electron transport layer, and the first buffer layer may include: depositing a thin film for a first hole injection layer, a thin film for a first hole transport layer, a first organic film, a thin film for a first electron transport layer, and a thin film for a first buffer layer on the substrate; applying a photosensitive resin to the entire surface of the substrate with the thin film for a first hole injection layer, the thin film for a first hole transport layer, the first organic film, the thin film for a first electron transport layer, and the thin film for a first buffer layer deposited thereon to form a first photosensitive resin layer; exposing and developing the first photosensitive resin layer to form a first photosensitive resin pattern made of the photosensitive resin at a position where a first light emitting is to be formed; and selectively etching the thin film for a first hole injection layer, the thin film for a first hole transport layer, the first organic film, the thin film for a first electron transport layer, and the thin film for a first buffer layer by using the first photosensitive resin pattern as a mask to form the first hole injection layer, the first hole transport layer, the first light emitting layer, the first electron transport layer, and the first buffer layer, which are formed of thin film for a first hole injection layer, the thin film for a first hole transport layer, the first organic film, the thin film for a first electron transport layer, and the thin film for a first buffer layer, respectively, on the substrate.

The forming of the second hole injection layer, the second hole transport layer, the second light emitting layer, the second electron transport layer, and the second buffer layer may include: depositing a thin film for a second hole injection layer, a thin film for a second hole transport layer, a second organic film, a thin film for a second electron transport layer, and a thin film for a second buffer layer on

the substrate; applying a photosensitive resin to the entire surface of the substrate with the thin film for a second hole injection layer, the thin film for a second hole transport layer, the second organic film, the thin film for a second electron transport layer, and the thin film for a second buffer layer deposited thereon to form a second photosensitive resin layer; exposing and developing the second photosensitive resin layer to form a second photosensitive resin pattern made of the photosensitive resin at a position where a second light emitting is to be formed; and selectively etching the thin film for a second hole injection layer, the thin film for a second hole transport layer, the second organic film, the thin film for a second electron transport layer, and the thin film for a second buffer layer by using the second photosensitive resin pattern as a mask to form the second hole injection layer, the second hole transport layer, the second light emitting layer, the second electron transport layer, and the second buffer layer, which are formed of thin film for a second hole injection layer, the thin film for a second hole transport layer, the second organic film, the thin film for a second electron transport layer, and the thin film for a second buffer layer, respectively, on the substrate.

The forming of the third hole injection layer, the third hole transport layer, the third light emitting layer, the third electron transport layer, and the third buffer layer may include: depositing a thin film for a third hole injection layer, a thin film for a third hole transport layer, a third organic film, a thin film for a third electron transport layer, and a thin film for a third buffer layer on the substrate; applying a photosensitive resin to the entire surface of the substrate with the thin film for a third hole injection layer, the thin film for a third hole transport layer, the third organic film, the thin film for a third electron transport layer, and the thin film for a third buffer layer deposited thereon to form a third photosensitive resin layer; exposing and developing the third photosensitive resin layer to form a third photosensitive resin pattern made of the photosensitive resin at a position where a third light emitting is to be formed; and selectively etching the thin film for a third hole injection layer, the thin film for a third hole transport layer, the third organic film, the thin film for a third electron transport layer, and the thin film for a third buffer layer by using the third photosensitive resin pattern as a mask to form the third hole injection layer, the third hole transport layer, the third light emitting layer, the third electron transport layer, and the third buffer layer, which are formed of thin film for a third hole injection layer, the thin film for a third hole transport layer, the third organic film, the thin film for a third electron transport layer, and the thin film for a third buffer layer, respectively, on the substrate.

The first, second, and third buffer layers may be made of a 1-2 Group and 12-16 Group metal oxide or 3-12 Group transition metal oxide.

According to another aspect of the present invention, there is provided a method for fabricating an organic light emitting diode (OLED) display device, including: (a) forming a fourth electrode on a substrate; (b) forming a first organic film and a first conductive film on the substrate with the fourth electrode formed thereon; (c) applying a photosensitive resin to the entire surface of the substrate with the first conductive film formed thereon to form a first photosensitive resin layer; (d) selectively exposing and developing the first photosensitive resin layer to form a first photosensitive resin pattern made of the photosensitive resin at a position at which a first light emitting is to be formed; (e) selectively removing the first conductive film by using the first photosensitive resin pattern as a mask to form a first

electrode; (f) removing the first photosensitive resin pattern and selectively removing the underlying exposed first organic film by using the first electrode as a mask to form a first light emitting layer formed of the first organic film; (g) forming a second light emitting layer and a second electrode on the substrate through the same processes as (b) to (f); and (h) forming a third light emitting layer and a third electrode on the substrate through the same processes as (b) to (f).

After a thin film for a first hole injection layer and a thin film for a first hole transport layer are formed on the substrate with the fourth electrode formed thereon, the first organic film may be formed, and after a thin film for a first electron transport layer is formed, the first conductive film may be formed.

As described above, in the case of the OLED display device and the method for fabricating the same according to embodiments of the present invention, since OLED pixels are patterned through a photolithography process, a large area patterning can be performed and a fine pitch can be obtained, and an organic compound layer can be protected by forming a buffer layer of a metal oxide on an upper portion of the organic compound layer or patterning the organic compound layer by using a cathode as a mask, improving device efficiency. Here, patterning through a photolithography process can be performed through a solution process, and since a light emitting layer is protected during a patterning process, a driving voltage and power consumption of the device can be reduced and efficiency can be enhanced.

Also, in the case of the OLED display device and the method for fabricating the same according to embodiments of the present invention, among red, green, and blue pixels, two pixels are patterned through a lift-off process and the other remaining one is deposited to be formed without patterning, the process can be simplified and efficiency can be increased.

The foregoing and other objects, features, aspects and advantages of the present invention will become more apparent from the following detailed description of the present invention when taken in conjunction with the accompanying drawings.

BRIEF DESCRIPTION OF THE DRAWINGS

FIG. 1 is a diagram illustrating a light emission principle of a general organic light emitting diode (OLED) display device.

FIG. 2 is an equivalent circuit diagram of a pixel in a general OLED display device.

FIGS. 3A through 3L are sequential sectional views illustrating a method for fabricating an OLED display device according to a first embodiment of the present invention.

FIGS. 4A through 4H are sequential sectional views illustrating a method for fabricating an OLED display device according to a second embodiment of the present invention.

FIGS. 5A through 5G are sequential sectional views illustrating a method for fabricating an OLED display device according to a third embodiment of the present invention.

FIG. 6 is a graph showing a state in which a life span of a device is shortened after a photolithography process is performed.

FIGS. 7A through 7K are sequential sectional views illustrating a method for fabricating an OLED display device according to a fourth embodiment of the present invention.

FIG. 8 is a sectional view showing another example of an OLED display device fabricated according to the fourth embodiment of the present invention illustrated in FIGS. 7A through 7K.

FIG. 9 is a sectional view showing another example of an OLED display device fabricated according to the fourth embodiment of the present invention illustrated in FIGS. 7A through 7K.

FIGS. 10A through 10H are sequential sectional views illustrating a method for fabricating an OLED display device according to a fifth embodiment of the present invention.

FIGS. 11A through 11H are sequential sectional views illustrating a method for fabricating an OLED display device according to a sixth embodiment of the present invention.

DETAILED DESCRIPTION OF THE INVENTION

Hereinafter, an organic light emitting diode (OLED) display device and a method for fabricating the same according to embodiments of the present invention will be described in detail with reference to the accompanying drawings such that they can be easily implemented by a person skilled in the art to which the present invention pertains. The present invention may be implemented in various forms without being limited to the embodiments described herein. Patterning of a large area with respect to an organic compound layer of an OLED display device cannot be handled by an existing method using a fine metal mask due to sagging of a substrate and a mask, so various large area patterning methods have been researched. Among them, the present invention proposes a patterning method through a photolithography process (referred to as a 'photo process', hereinafter), and here, the photo process is advantageous in that it is available for large area patterning and obtaining a fine pitch, and available for an application of a solution process.

FIGS. 3A through 3L are sequential sectional views illustrating a method for fabricating an OLED display device according to a first embodiment of the present invention, in which a method for fabricating an OLED diode with respect to some pixels is taken as an example.

Here, a method for fabricating an OLED with respect to a pixel including 2T1C (two transistors and one capacitor) is taken as an example for the description purpose, but the present invention is not limited thereto.

First, although not shown, in an OLED display device according to a first embodiment of the present invention, a gate line including a first gate electrode and a storage electrode including a second gate electrode may be formed on a substrate 110 made of an insulating material such as transparent glass, plastic, or the like.

A gate insulating layer made of silicon nitride (SiN_x), silicon oxide (SiO₂), or the like, may be formed on the gate line including the first gate electrode and the storage electrode including the second electrode.

A first active layer and a second active layer, made of semiconductor, may be formed on the gate insulating layer. The first active layer and the second active layer may be positioned on the first gate electrode and the second gate electrode, respectively.

A data line, a driving voltage line, a first source/drain electrode, and a second source/drain electrode may be formed on an upper portion of the first active layer and the second active layer.

A predetermined passivation layer may be formed on the substrate **110** on which the data line, the driving voltage line, the first source/drain electrode, and the second source/drain electrode have been formed.

As shown in FIG. 3A, a pixel electrode **120** and a connecting electrode (not shown) may be formed on the substrate **110** with the passivation film formed thereon. The pixel electrode **120** and the connecting electrode may be made of a transparent conductive material such as indium tin oxide (ITO) or a reflective conductive material such as aluminum, silver, or an alloy thereof.

The pixel electrode **120** as an anode may be electrically connected to the second drain electrode through a second contact hole, and the connecting electrode may electrically connect the first drain electrode and the second gate electrode through a first contact hole and a third contact hole.

A partition (not shown) may be formed on the substrate **110** with the pixel electrode **120** formed thereon. Here, the partition may encompass the edges of the pixel electrode **120**, like a bank, to define an opening, and may be made of an organic insulating material or an inorganic insulating material.

An organic compound layer may be formed on the substrate **110**.

Here, the organic compound layer may have a multilayer structure including an auxiliary layer in order to enhance luminous efficiency of a light emitting layer that emits light, besides the light emitting layer. The auxiliary layer may include an electron transport layer and a hole transport layer for balancing electrons and holes and an electron injection layer and a hole injection layer for strengthening injection of electrons and holes.

The organic compound layer may be formed through a photo process and a lift-off process, and to this end, as shown in FIG. 3B, a first organic film **151** is deposited on the substrate **110**.

Here, the first organic film **151** may be deposited after the hole injection layer and the hole transport layer are formed on the substrate **110**, and here, the first organic film **151** may be deposited to form a red, green, or blue light emitting layer.

The hole injection layer may facilitate injection of holes from the pixel electrode **120**, and the hole transport layer serves to allow holes to be transported to the light emitting layer.

Thereafter, as shown in FIG. 3C, a photosensitive resin (or photoresist) is coated on the entire surface of the substrate **110** with the first organic film **151** deposited thereon, to form a first photosensitive resin layer **191**.

Ultraviolet rays are selectively irradiated (exposure) to the first photosensitive resin layer **191** through a certain mask (not shown).

Thereafter, when the first photosensitive resin layer **191** exposed through the mask is developed, a first photosensitive resin pattern **190a** made of the photosensitive resin remains only at a position where a first light emitting layer is to be formed as shown in FIG. 3D.

A photosensitive resin developing solution is used for the developing operation, and here, any developing solution may be used as long as it does not dissolve a material of the light emitting layer. For example, a generally used organic alkali-based developing solution may be used, or an inorganic alkali-based developing solution or an aqueous solution capable of developing resist may be used.

Thereafter, as shown in FIG. 3E, a partial region of the first organic film formed under the first photosensitive resin pattern **190a** is selectively etched by using the first photo-

sensitive resin pattern **190a** as a mask, to form a first light emitting layer **150a** formed of the first organic film on the substrate **110** (first photo process).

Here, for example, the first light emitting layer **150a** may be a red light emitting layer, and the etching may include wet etching as well as dry etching. However, the present invention is not limited thereto and the first light emitting layer **150a** may be a red or blue light emitting layer.

Thereafter, as shown in FIG. 3F, with the first photosensitive resin pattern **190a** remaining, a second organic film **152** is deposited thereon.

A follow-up process is substantially the same as the first photo process for forming the first light emitting layer **150a**. Namely, as shown in FIG. 3G, a photosensitive resin is coated on the entire surface of the substrate **110** with the second organic film **152** formed thereon, to form a second photosensitive resin layer **192**.

Thereafter, UV rays are selectively irradiated to the second photosensitive resin layer **192** through a certain mask (not shown).

Thereafter, when the second photosensitive resin layer **192** exposed through the mask is developed, a second photosensitive resin pattern **190b** made of the photosensitive resin remains only at a position where a second light emitting layer is to be formed as shown in FIG. 3H.

Thereafter, as shown in FIG. 3I, a partial region of the first organic film formed under the second photosensitive resin pattern **190b** is selectively etched by using the second photosensitive resin pattern **190b** as a mask, to form a second light emitting layer **150b** formed of the second organic film on the substrate **110** (second photo process).

Here, for example, the second emitting layer **150b** may be a green light emitting layer, and the etching may include wet etching as well as dry etching. However, the present invention is not limited thereto and when the first light emitting layer **150a** is a red light emitting layer, the second light emitting layer **150b** may be a blue light emitting layer, other than a green light emitting layer.

Thereafter, as shown in FIG. 3J, with the first photosensitive resin pattern **190a** and the second photosensitive resin pattern **190b** remaining, a third organic film **153** is deposited thereon.

As a follow-up process, a lift-off process, rather than a photo process such as the first and second photo processes as described above, is used. Namely, as shown in FIG. 3K, the first photosensitive resin pattern and the second photosensitive resin pattern are removed through a lift-off process, and here, the third organic film remaining on upper portions of the first light emitting layer **150a** and the second light emitting layer **150b** is removed along with the first photosensitive resin pattern and the second photosensitive resin pattern.

As a result, a third light emitting layer **150c** formed of the third organic film is formed between the first light emitting layer **150a** and the second light emitting layer **150b**.

Here, for example, when the first light emitting layer **150a** is a red light emitting layer and the second light emitting layer **150b** is a green light emitting layer, the third light emitting layer **150c** may be a blue light emitting layer. Also, when the first light emitting layer **150a** is a red light emitting layer and the second light emitting layer **150b** is a blue light emitting layer, the third light emitting layer **150c** may be a green light emitting layer. However, the present invention is not limited thereto and the first light emitting layer **150a**, the second light emitting layer **150b**, and the third light emitting layer **150c** may be configured as red, green, and blue light emitting layers irrespective of order.

Thereafter, as shown in FIG. 3L, a common electrode **180** as a cathode may be formed on the first light emitting layer **150a**, the second light emitting layer **150b**, and the third light emitting layer **150c**. Here, the common electrode, which receives a common voltage, may be made of a reflective conductive material including calcium (Ca), barium (Ba), magnesium (Mg), aluminum (Al), silver (Ag), or the like, or a transparent conductive material such as ITO, IZO, or the like.

Here, the foregoing common electrode **180** may be formed after the electron transport layer and the electron injection layer are formed on the substrate **110**.

The electron injection layer facilitates injection of electrons from the common electrode **180**, and the electron transport layer serves to allow electrons to move to the light emitting layers **150a**, **150b**, and **150c**.

In this manner, in the case of the first embodiment of the present invention, since a single photo process, namely, a single photosensitive resin coating, exposing, developing, and etching process (a total of four processes) may be omitted, and thus, the process can be simplified. Also, since OLED pixels are patterned through the photo process, large patterning can be performed and high pitch can be obtained, and in addition, a solution process can be performed.

In the OLED display device configured as described above, the first gate electrode connected to the gate line and the first source electrode and the first drain electrode connected to the data line may constitute a first switching thin film transistor (TFT) along with the first active layer. Also, the second gate electrode connected to the first drain electrode, the second source electrode connected to the driving voltage line, and the second drain electrode connected to the pixel electrode **120** may constitute a driving TFT along with the second active layer.

Also, the pixel electrode **120**, the light emitting layers **150a**, **150b**, and **150c**, and the common electrode **180** may constitute an OLED, and the mutually overlapping storage electrode and driving voltage line may constitute a storage capacitor.

However, as mentioned above, when the organic compound layer is patterned through the photo process, the organic compound layer may be likely to be damaged by a photosensitive resin, a developing solution, and a strip solution, which may result in a degradation of efficiency and a life span.

Thus, in case of second and third embodiments of the present invention, a buffer layer made of metal oxide is formed on an upper portion of the organic compound layer to protect the organic compound layer against a photo process. This will be described in detail with reference to the accompanying drawings.

FIGS. 4A through 4H are sequential sectional views illustrating a method for fabricating an OLED display device according to a second embodiment of the present invention, in which a method for fabricating an OLED diode with respect to some pixels is taken as an example.

Although not shown, as mentioned above, in an OLED display device according to a second embodiment of the present invention, a gate line including a first gate electrode and a storage electrode including a second gate electrode may be formed on a substrate **210** made of an insulating material such as transparent glass, plastic, or the like.

A gate insulating layer made of silicon nitride (SiNx), silicon oxide (SiO₂), or the like, may be formed on the gate line including the first gate electrode and the storage electrode including the second electrode.

A first active layer and a second active layer, made of semiconductor, may be formed on the gate insulating layer. The first active layer and the second active layer may be positioned on the first gate electrode and the second gate electrode, respectively.

A data line, a driving voltage line, a first source/drain electrode, and a second source/drain electrode may be formed on an upper portion of the first active layer and the second active layer.

A predetermined passivation layer may be formed on the substrate **210** on which the data line, the driving voltage line, the first source/drain electrode, and the second source/drain electrode have been formed.

As shown in FIG. 4A, a pixel electrode **220** and a connecting electrode (not shown) may be formed on the substrate **210** with the passivation film formed thereon. The pixel electrode **220** and the connecting electrode may be made of a transparent conductive material such as indium tin oxide (ITO) or a reflective conductive material such as aluminum, silver, or an alloy thereof.

The pixel electrode **220** as an anode may be electrically connected to the second drain electrode through a second contact hole, and the connecting electrode may electrically connect the first drain electrode and the second gate electrode through a first contact hole and a third contact hole.

A partition (not shown) may be formed on the substrate **210** with the pixel electrode **220** formed thereon. Here, the partition may encompass the edges of the pixel electrode **220**, like a bank, to define an opening, and may be made of an organic insulating material or an inorganic insulating material.

An organic compound layer may be formed on the substrate **210**.

Here, the organic compound layer may have a multilayer structure including an auxiliary layer in order to enhance luminous efficiency of a light emitting layer that emits light, besides the light emitting layer. The auxiliary layer may include an electron transport layer and a hole transport layer for balancing electrons and holes and an electron injection layer and a hole injection layer for strengthening injection of electrons and holes.

Namely, as shown in FIG. 4A, a thin film **231** for a first hole injection layer, a thin film **241** for a first hole transport layer, a first organic film **251**, a thin film **261** for a first electron transport layer, and a thin film **271** for a first buffer layer are sequentially deposited on the substrate **210** with the pixel electrode **220** formed thereon.

Here, the thin film **261** for a first electron transport layer may include a thin film for a first electron injection layer, and the thin film **271** for a first buffer layer may be made of a 1-2 Group and 12-16 Group metal oxide or 3-12 Group transition metal oxide.

Thereafter, as shown in FIG. 4B, a photosensitive resin is coated on the entire surface of the substrate **210** on which the thin film **231** for a first hole injection layer, the thin film **241** for a first hole transport layer, the first organic film **251**, the thin film **261** for a first electron transport layer, and the thin film **271** for a first buffer layer are deposited, in order to form a first photosensitive resin layer **291**.

UV light is selectively irradiated to the first photosensitive resin layer **291** through a certain mask (not shown).

Thereafter, when the first photosensitive resin layer **291** exposed through the mask is developed, a first photosensitive resin pattern **290a** made of the photosensitive resin remains only at a position where a first light emitting layer is to be formed as shown in FIG. 4C.

Thereafter, as shown in FIG. 4D, partial regions of the thin film for a first hole injection layer, the thin film for a first hole transport layer, the first organic film, the thin film for a first electron transport layer, and the thin film for a first buffer layer formed under the first photosensitive resin pattern **290a** are selectively etched by using the first photosensitive resin pattern **290a** as a mask, in order to form a first hole injection layer **230a**, a first hole transport layer **240a**, a first light emitting layer **250a**, a first electron transport layer **260a**, and a first buffer layer **270a** formed of the thin film for a first hole injection layer, the thin film for a first hole transport layer, the first organic film, the thin film for a first electron transport layer, and the thin film for a first buffer layer, respectively, on the substrate **210** (first photo process).

In this manner, since the first buffer layer **270a** is positioned on the upper portion of the organic compound layer, namely, on the first electron transport layer **260a**, the organic compound layer, in particular, the first electron transport layer **260a**, is prevented from being degraded, thus preventing a degradation of the device.

Also, since the first buffer layer **270a** of metal oxide is applied, an energy barrier between the first electron transport layer **260a** and the common electrode can be lowered, enhancing efficiency and a life span.

Here, for example, the first light emitting layer **250a** may be a red light emitting layer, and the etching may include wet etching, as well as dry etching. However, the present invention is not limited thereto and the first light emitting layer **250a** may be a green or blue light emitting layer.

Thereafter, as shown in FIG. 4E, the first photosensitive resin pattern is removed.

Thereafter, as shown in FIG. 4F, a second hole injection layer **230b**, a second hole transport layer **240b**, a second light emitting layer **250b**, a second electron transport layer **260b**, and a second buffer layer **270b**, which are formed of a thin film for a second hole injection layer, a thin film for a second hole transport layer, a second organic film, a thin film for a second electron transport layer, and a thin film for a second buffer layer, respectively, are formed on the substrate **210** through a second photo process which is substantially the same as the first photo process as mentioned above.

Here, for example, the second light emitting layer **250b** may be a green light emitting layer. However, the present invention is not limited thereto and when the first light emitting layer **250a** is a red light emitting layer, the second light emitting layer **250b** may be a blue light emitting layer, other than a green light emitting layer.

Thereafter, as shown in FIG. 4G, a third hole injection layer **230c**, a third hole transport layer **240c**, a third light emitting layer **250c**, a third electron transport layer **260c**, and a third buffer layer **270c**, which are formed of a thin film for a third hole injection layer, a thin film for a third hole transport layer, a third organic film, a thin film for a third electron transport layer, and a thin film for a third buffer layer, respectively, are formed on the substrate **210** through a third photo process which is substantially the same as the first and second photo processes as mentioned above.

Here, for example, when the first light emitting layer **250a** is a red light emitting layer and the second light emitting layer **250b** is a green light emitting layer, the third light emitting layer **250c** may be a blue light emitting layer. Also, when the first light emitting layer **250a** is a red light emitting layer and the second light emitting layer **250b** is a blue light emitting layer, the third light emitting layer **250c** may be a green light emitting layer. However, the present invention is not limited thereto and the first light emitting layer **250a**, the

second light emitting layer **250b**, and the third light emitting layer **250c** may be configured as red, green, and blue light emitting layers irrespective of order.

Thereafter, as shown in FIG. 4H, common electrodes **280a**, **280b**, and **280c** as cathodes may be formed on the first buffer layer **270a**, the second buffer layer **270b**, and the third buffer layer **270c**. Here, the common electrodes **280a**, **280b**, and **280c**, which receive a common voltage, may be made of a reflective conductive material including calcium (Ca), barium (Ba), magnesium (Mg), aluminum (Al), silver (Ag), or the like, or a transparent conductive material such as ITO, IZO, or the like.

In the OLED display device configured as described above, the first gate electrode connected to the gate line and the first source electrode and the first drain electrode connected to the data line may constitute a first switching thin film transistor (TFT) along with the first active layer. Also, the second gate electrode connected to the first drain electrode, the second source electrode connected to the driving voltage line, and the second drain electrode connected to the pixel electrode **220** may constitute a driving TFT along with the second active layer.

Also, the pixel electrode **220**, the light emitting layers **250a**, **250b**, and **250c**, and the common electrodes **280a**, **280b**, and **280c** may constitute an OLED, and the mutually overlapping storage electrode and driving voltage line may constitute a storage capacitor.

FIGS. 5A through 5G are sequential sectional views illustrating a method for fabricating an OLED display device according to a third embodiment of the present invention, in which a method for fabricating an OLED diode with respect to some pixels is taken as an example.

Although not shown, as mentioned above, in an OLED display device according to a third embodiment of the present invention, a gate line including a first gate electrode and a storage electrode including a second gate electrode may be formed on a substrate **310** made of an insulating material such as transparent glass, plastic, or the like.

A gate insulating layer made of silicon nitride (SiN_x), silicon oxide (SiO₂), or the like, may be formed on the gate line including the first gate electrode and the storage electrode including the second electrode.

A first active layer and a second active layer, made of semiconductor, may be formed on the gate insulating layer. The first active layer and the second active layer may be positioned on the first gate electrode and the second gate electrode, respectively.

A data line, a driving voltage line, a first source/drain electrode, and a second source/drain electrode may be formed on an upper portion of the first active layer and the second active layer.

A predetermined passivation layer may be formed on the substrate **310** on which the data line, the driving voltage line, the first source/drain electrode, and the second source/drain electrode have been formed.

As shown in FIG. 5A, a pixel electrode **320** and a connecting electrode (not shown) may be formed on the substrate **310** with the passivation film formed thereon. The pixel electrode **320** and the connecting electrode may be made of a transparent conductive material such as indium tin oxide (ITO) or a reflective conductive material such as aluminum, silver, or an alloy thereof.

The pixel electrode **320** as an anode may be electrically connected to the second drain electrode through a second contact hole, and the connecting electrode may electrically connect the first drain electrode and the second gate electrode through a first contact hole and a third contact hole.

A partition (not shown) may be formed on the substrate **310** with the pixel electrode **320** formed thereon. Here, the partition may encompass the edges of the pixel electrode **320**, like a bank, to define an opening, and may be made of an organic insulating material or an inorganic insulating material.

An organic compound layer may be formed on the substrate **310**. Here, in the case of the third embodiment of the present invention, unlike the second embodiment of the present invention as described above, the organic compound layer is formed through a lift-off process.

Namely, as shown in FIG. **5A**, a photosensitive resin is coated on the entire surface of the substrate **310** with the pixel electrode **320** formed thereon, to form a first photosensitive resin layer **391**.

UV light is selectively irradiated to the first photosensitive resin layer **391** through a certain mask (not shown).

Thereafter, when the first photosensitive resin layer **391** exposed through the mask is developed, a first photosensitive resin pattern **390a** made of the photosensitive resin remains only at a position other than a position where a first light emitting layer is to be formed as shown in FIG. **5B**.

Thereafter, as shown in FIG. **5C**, with the first photosensitive resin pattern **390a** remaining, a thin film **331** for a first hole injection layer, a thin film **341** for a first hole transport layer, a first inorganic film **351**, a thin film **361** for a first electron transport layer, and a thin film **371** for a first buffer layer are deposited on the first photosensitive resin pattern **390a**.

Here, the thin film **361** for a first electron transport layer may include a thin film for a first electron injection layer, and the thin film **371** for a first buffer layer may be made of a 1-2 Group and 12-16 Group metal oxide or 3-12 Group transition metal oxide.

Thereafter, as shown in FIG. **5D**, the first photosensitive resin pattern **390a** is removed through a first lift-off process. Here, the thin film for a first hole injection layer, the thin film for a first hole transport layer, the first organic film, the thin film for the first electron transport layer, and the thin film for a first buffer layer remaining on the upper portion of the first photosensitive resin pattern **390a** are also removed together with the first photosensitive resin pattern **390a**.

As a result, a first hole injection layer **330**, a first hole transport layer **340a**, a first light emitting layer **350a**, a first electron transport layer **360a**, and a first buffer layer **370a**, which are formed of the thin film for a first hole injection layer, the thin film for a first hole transport layer, the first organic film, the thin film for the first electron transport layer, and the thin film for a first buffer layer, respectively, are formed on the substrate **310**.

Here, for example, the first light emitting layer **350a** may be a red light emitting layer. However, the present invention is not limited thereto and the first light emitting layer **350a** may be a green or blue light emitting layer.

Thereafter, as shown in FIG. **5E**, a second hole injection layer **330b**, a second hole transport layer **340b**, a second light emitting layer **350b**, a second electron transport layer **360b**, and a second buffer layer **370b**, which are formed of a thin film for a second hole injection layer, a thin film for a second hole transport layer, a second organic film, a thin film for a second electron transport layer, and a thin film for a second buffer layer, respectively, are formed on the substrate **310** through a second lift-off process which is substantially the same as the first lift-off process as mentioned above.

Here, for example, the second light emitting layer **350b** may be a green light emitting layer. However, the present

invention is not limited thereto and when the first light emitting layer **350a** is a red light emitting layer, the second light emitting layer **350b** may be a blue light emitting layer, other than a green light emitting layer.

Thereafter, as shown in FIG. **5F**, a third hole injection layer **330c**, a third hole transport layer **340c**, a third light emitting layer **350c**, a third electron transport layer **360c**, and a third buffer layer **370c**, which are formed of a thin film for a third hole injection layer, a thin film for a third hole transport layer, a third organic film, a thin film for a third electron transport layer, and a thin film for a third buffer layer, respectively, are formed on the substrate **310** through a third lift-off process which is substantially the same as the first and second lift-off processes as mentioned above.

Here, for example, when the first light emitting layer **350a** is a red light emitting layer and the second light emitting layer **350b** is a green light emitting layer, the third light emitting layer **350c** may be a blue light emitting layer. Also, when the first light emitting layer **350a** is a red light emitting layer and the second light emitting layer **350b** is a blue light emitting layer, the third light emitting layer **350c** may be a green light emitting layer. However, the present invention is not limited thereto and the first light emitting layer **350a**, the second light emitting layer **350b**, and the third light emitting layer **350c** may be configured as red, green, and blue light emitting layers irrespective of order.

Thereafter, as shown in FIG. **5G**, common electrodes **380a**, **380b**, and **380c** as cathodes may be formed on the first light emitting layer **350a**, the second light emitting layer **350b**, and the third light emitting layer **350c**. Here, the common electrodes **380a**, **380b**, and **380c**, which receive a common voltage, may be made of a reflective conductive material including calcium (Ca), barium (Ba), magnesium (Mg), aluminum (Al), silver (Ag), or the like, or a transparent conductive material such as ITO, IZO, or the like.

In the OLED display device configured as described above, the first gate electrode connected to the gate line and the first source electrode and the first drain electrode connected to the data line may constitute a first switching thin film transistor (TFT) along with the first active layer. Also, the second gate electrode connected to the first drain electrode, the second source electrode connected to the driving voltage line, and the second drain electrode connected to the pixel electrode **320** may constitute a driving TFT along with the second active layer.

Also, the pixel electrode **320**, the light emitting layers **350a**, **350b**, and **350c**, and the common electrodes **380a**, **380b**, and **380c** may constitute an OLED, and the mutually overlapping storage electrode and driving voltage line may constitute a storage capacitor.

Meanwhile, organic substances whose efficiency and life span are rapidly reduced after the photo process is performed are included in the organic compound layer. For example, in the case of a blue light emitting layer, device efficiency tends to be reduced from about 5.3 cd/A to 2.0 cd/A after a photo process based on 1000 nit.

For example, referring to FIG. **6**, there is an organic substance whose life span is rapidly reduced after a photo process exists, which leads to a reduction in efficiency and life span of the LED display device.

Thus, in case of a fourth embodiment of the present invention, two pixels among red, green, and blue pixels are patterned through a lift-off process, while the other remaining one pixel is deposited to be formed without patterning, to thus simplify the process and increase efficiency. This will be described in detail with reference to the accompanying drawings.

FIGS. 7A through 7K are sequential sectional views illustrating a method for fabricating an OLED display device according to a fourth embodiment of the present invention, in which a method for fabricating an OLED diode with respect to some pixels is taken as an example.

Although not shown, as mentioned above, in an OLED display device according to a third embodiment of the present invention, a gate line including a first gate electrode and a storage electrode including a second gate electrode may be formed on a substrate **410** made of an insulating material such as transparent glass, plastic, or the like.

A gate insulating layer made of silicon nitride (SiN_x), silicon oxide (SiO₂), or the like, may be formed on the gate line including the first gate electrode and the storage electrode including the second electrode.

A first active layer and a second active layer, made of semiconductor, may be formed on the gate insulating layer. The first active layer and the second active layer may be positioned on the first gate electrode and the second gate electrode, respectively.

A data line, a driving voltage line, a first source/drain electrode, and a second source/drain electrode may be formed on an upper portion of the first active layer and the second active layer.

A predetermined passivation layer may be formed on the substrate **410** on which the data line, the driving voltage line, the first source/drain electrode, and the second source/drain electrode have been formed.

As shown in FIG. 7A, a pixel electrode **420** and a connecting electrode (not shown) may be formed on the substrate **410** with the passivation film formed thereon. The pixel electrode **420** and the connecting electrode may be made of a transparent conductive material such as indium tin oxide (ITO) or a reflective conductive material such as aluminum, silver, or an alloy thereof.

The pixel electrode **420** as an anode may be electrically connected to the second drain electrode through a second contact hole, and the connecting electrode may electrically connect the first drain electrode and the second gate electrode through a first contact hole and a third contact hole.

A partition (not shown) may be formed on the substrate **410** with the pixel electrode **420** formed thereon. Here, the partition may encompass the edges of the pixel electrode **420**, like a bank, to define an opening, and may be made of an organic insulating material or an inorganic insulating material.

An organic compound layer may be formed on the substrate **410**. Here, in the case of the fourth embodiment of the present invention, two pixels among red, green, and blue pixels are patterned through a lift-off process, while the other remaining one pixel is deposited to be formed without patterning, to form the organic compound layer.

Namely, as shown in FIG. 7A, a hole injection layer **430** and a hole transport layer **440** are formed on the substrate **410** with the pixel electrode **420** formed thereon.

As mentioned above, the hole injection layer **430** may facilitate injection of holes from the pixel electrode **420**, and the hole transport layer **440** serves to allow holes to be transported to the light emitting layer.

Thereafter, as shown in FIG. 7B, a photosensitive resin is coated on the entire surface of the substrate **410** with the hole injection layer **430** and the hole transport layer **440** formed thereon, to form a first photosensitive resin layer **491**.

UV light is selectively irradiated to the first photosensitive resin layer **491** through a certain mask (not shown).

Thereafter, when the first photosensitive resin layer **491** exposed through the mask is developed, a first photosensitive resin pattern **490a** made of the photosensitive resin remains only at a position other than a position where a first light emitting layer is to be formed as shown in FIG. 7C.

Thereafter, as shown in FIG. 7D, with the first photosensitive resin pattern **490a** remaining, a first organic film **451** is deposited thereon.

Thereafter, as shown in FIG. 7E, the first photosensitive resin pattern **490a** is removed through a first lift-off process. Here, the first organic film **451** remaining on the upper portion of the first photosensitive resin pattern **490a** is also removed together with the first photosensitive resin pattern **490a**.

As a result, a first light emitting layer **450a** formed of the first organic film is formed on the substrate **410**.

Here, for example, the first light emitting layer **450a** may be a red light emitting layer. However, the present invention is not limited thereto and the first light emitting layer **450a** may be a green or blue light emitting layer.

As shown in FIG. 7F, a second photosensitive resin layer **492** may be formed by applying a photosensitive resin to the entire surface of the substrate **410** with the first light emitting layer **450a** formed thereon in the substantially same manner.

And then, UV light is selectively irradiated to the second photosensitive resin layer **492** through a certain mask (not shown).

Thereafter, when the second photosensitive resin layer **492** exposed through the mask is developed, a second photosensitive resin pattern **490b** made of the photosensitive resin remains only at a position other than a position where a second light emitting layer is to be formed as shown in FIG. 7G.

Thereafter, as shown in FIG. 7H, with the second photosensitive resin pattern **490b** remaining, a second organic film **452** is deposited thereon.

Thereafter, as shown in FIG. 7I, the second photosensitive resin pattern **490b** is removed through second first lift-off process. Here, the second organic film **452** remaining on the upper portion of the second photosensitive resin pattern **490b** is also removed together with the second photosensitive resin pattern **490b**.

As a result, a second light emitting layer **450b** formed of the second organic film is formed on the substrate **410**.

Here, for example, the second emitting layer **450b** may be a green light emitting layer. However, the present invention is not limited thereto and when the first light emitting layer **450a** is a red light emitting layer, the second light emitting layer **450b** may be a blue light emitting layer, other than a green light emitting layer.

As shown in FIG. 7J, a third organic film is deposited on the entire surface of the substrate **410** with the first light emitting layer **450a** and the second light emitting layer **450b** formed thereon, to form a third light emitting layer **450c**.

Here, the third light emitting layer **450c** may be formed with a certain thickness on upper portions of the first light emitting layer **450a** and the second light emitting layer **450b** as well as between the first light emitting layer **450a** and the second light emitting layer **450b**.

Here, for example, when the first light emitting layer **450a** is a red light emitting layer and the second light emitting layer **450b** is a green light emitting layer, the third light emitting layer **450c** may be a blue light emitting layer. Also, when the first light emitting layer **450a** is a red light emitting layer and the second light emitting layer **450b** is a blue light emitting layer, the third light emitting layer **450c** may be a green light emitting layer. However, the present invention is

not limited thereto and the first light emitting layer **450a**, the second light emitting layer **450b**, and the third light emitting layer **450c** may be configured as red, green, and blue light emitting layers irrespective of order.

Thereafter, as shown in FIG. 7K, an electron transport layer **460** and a common electrode **480** as a cathode are formed on the substrate **410** on which the first light emitting layer **450a**, the second light emitting layer **450b**, and the third light emitting layer **450c** have been formed.

Here, the electron transport layer **460** may include an electron injection layer. The common electrode **480**, which receives a common voltage, may be made of a reflective conductive material including calcium (Ca), barium (Ba), magnesium (Mg), aluminum (Al), silver (Ag), or the like, or a transparent conductive material.

In the OLED display device configured as described above, the first gate electrode connected to the gate line and the first source electrode and the first drain electrode connected to the data line may constitute a first switching thin film transistor (TFT) along with the first active layer. Also, the second gate electrode connected to the first drain electrode, the second source electrode connected to the driving voltage line, and the second drain electrode connected to the pixel electrode **220** may constitute a driving TFT along with the second active layer.

Also, the pixel electrode **420**, the light emitting layers **450a**, **450b**, and **450c**, and the common electrode **480** may constitute an OLED, and the mutually overlapping storage electrode and driving voltage line may constitute a storage capacitor.

In this manner, for example, when the first light emitting layer **450a**, the second light emitting layer **450b**, and the third light emitting layer **450c** are a red light emitting layer, a green light emitting layer, and a blue light emitting layer, respectively, the red light emitting layer and the green light emitting layer are patterned through a lift-off process and the blue light emitting layer may be commonly formed on the entire surface.

However, the present invention is not limited thereto. Namely, the green light emitting layer and the blue light emitting layer may be patterned through a lift-off process while the red light emitting layer may be commonly formed on the entire surface, or the red light emitting layer and the blue light emitting layer may be patterned through a lift-off process while the green light emitting layer may be commonly formed on the entire surface.

FIG. 8 is a sectional view showing another example of an OLED display device fabricated according to the fourth embodiment of the present invention illustrated in FIGS. 7A through 7K, in which a first organic film is deposited on the entire surface of the substrate **410** with the second light emitting layer **450b** and the third light emitting layer **450c** formed thereon, to form the first light emitting layer **450a**.

Here, the first light emitting layer **450a** is formed with a certain thickness even on upper portions of the second light emitting layer **450b** and the third light emitting layer **450c**, as well as between the second light emitting layer **450b** and the third light emitting layer **450c**.

FIG. 9 is a sectional view showing another example of an OLED display device fabricated according to the fourth embodiment of the present invention illustrated in FIGS. 7A through 7K, in which a second inorganic film is deposited on the entire surface of the substrate **410** with the first light emitting layer **450a** and the third light emitting layer **450c** formed thereon, to form the second light emitting layer **450b**.

Here, the second light emitting layer **450b** is formed with a certain thickness even on upper portions of the first light emitting layer **450a** and the third light emitting layer **450c**, as well as between the first light emitting layer **450a** and the third light emitting layer **450c**.

Meanwhile, damage to an organic compound layer due to a photo process may be prevented according to other methods than those of the second and third embodiments of the present invention. Namely, an organic compound layer may be protected against a photo process by patterning the organic compound layer by using a cathode as a mask. This will be described in detail according to fifth and sixth embodiments of the present invention.

FIGS. 10A through 10H are sequential sectional views illustrating a method for fabricating an OLED display device according to a fifth embodiment of the present invention.

Although not shown, in an OLED display device according to a fifth embodiment of the present invention, a gate line including a first gate electrode and a storage electrode including a second gate electrode may be formed on a substrate **510** made of an insulating material such as transparent glass, plastic, or the like.

A gate insulating layer made of silicon nitride (SiN_x), silicon oxide (SiO₂), or the like, may be formed on the gate line including the first gate electrode and the storage electrode including the second electrode.

A first active layer and a second active layer, made of semiconductor, may be formed on the gate insulating layer. The first active layer and the second active layer may be positioned on the first gate electrode and the second gate electrode, respectively.

A data line, a driving voltage line, a first source/drain electrode, and a second source/drain electrode may be formed on an upper portion of the first active layer and the second active layer.

A predetermined passivation layer may be formed on the substrate **510** on which the data line, the driving voltage line, the first source/drain electrode, and the second source/drain electrode have been formed.

As shown in FIG. 10A, a pixel electrode **520** and a connecting electrode (not shown) may be formed on the substrate **510** with the passivation film formed thereon. The pixel electrode **520** and the connecting electrode may be made of a transparent conductive material such as indium tin oxide (ITO) or a reflective conductive material such as aluminum, silver, or an alloy thereof.

The pixel electrode **520** as an anode may be electrically connected to the second drain electrode through a second contact hole, and the connecting electrode may electrically connect the first drain electrode and the second gate electrode through a first contact hole and a third contact hole.

A partition (not shown) may be formed on the substrate **510** with the pixel electrode **520** formed thereon. Here, the partition may encompass the edges of the pixel electrode **520**, like a bank, to define an opening, and may be made of an organic insulating material or an inorganic insulating material.

An organic compound layer may be formed on the substrate **510**.

Here, the organic compound layer may have a multilayer structure including an auxiliary layer in order to enhance luminous efficiency of a light emitting layer that emits light, besides the light emitting layer. The auxiliary layer may include an electron transport layer and a hole transport layer for balancing electrons and holes and an electron injection layer and a hole injection layer for strengthening injection of electrons and holes.

Namely, as shown in FIG. 10B, a thin film **531** for a first hole injection layer, a thin film **541** for a first hole transport layer, a first organic film **551**, a thin film **561** for a first electron transport layer, and a first conductive film **581** are sequentially deposited on the substrate **510** with the pixel electrode **520** formed thereon.

Here, the thin film **561** for a first electron transport layer may include a thin film for a first electron injection layer, and the first conductive film **581** may be made of a reflective conductive material including calcium (Ca), barium (Ba), magnesium (Mg), aluminum (Al), silver (Ag), or the like, or a transparent conductive material such as ITO, IZO, or the like.

Thereafter, as shown in FIG. 10C, a photosensitive resin is coated on the entire surface of the substrate **510**, on which the thin film **531** for a first hole injection layer, the thin film **541** for a first hole transport layer, the first organic film **551**, the thin film **561** for a first electron transport layer, and the first conductive film **581** have been deposited, to form a first photosensitive resin layer **591**.

Thereafter, UV rays are selectively irradiated to the first photosensitive resin layer **591** through a certain mask M.

Thereafter, when the first photosensitive resin layer **591** exposed through the mask M is developed, a first photosensitive resin pattern **590a** made of the photosensitive resin remains only at a position where a first light emitting layer is to be formed as shown in FIG. 10D.

Here, the first photosensitive resin pattern **590a** may be patterned to have at least the same width as that of the underlying pixel electrode **520** in consideration of an alignment error of the mask M and other processing errors.

Thereafter, as shown in FIG. 10E, when a partial region of first conductive film formed under the first photosensitive resin pattern **590a** is selectively etched by using the first photosensitive resin pattern **590a** as a mask, a first common electrode **580a** formed of the first conductive film is formed at a position where the first light emitting layer is to be formed.

Here, the etching may include wet etching as well as dry etching.

Thereafter, as shown in FIG. 10F, a remnant of the first photosensitive resin pattern is removed through ashing, stripping, or the like, and here, as partial regions of the thin film for a first hole injection layer, the thin film for a first hole transport layer, the first organic film, and the thin film for a first electron transport layer exposed thereunder are selectively removed by using the first common electrode **580a** as a mask, a first hole injection layer **530a**, a first hole transport layer **540a**, a first light emitting layer **550a**, and a first electron transport layer **560a**, which are formed of the thin film for a first hole injection layer, the thin film for a first hole transport layer, the first organic film, and the thin film for a first electron transport layer, respectively, are formed (a first photo process).

In this manner, since the first common electrode **580a** is positioned as a barrier layer on an upper portion of the organic compound layer, namely, on the first electron transport layer **560a**, the organic compound layer, in particular, the first electron transport layer **560a**, can be prevented from being degraded during the photo process, thus preventing a degradation of the device.

Here, the first light emitting layer **550a** may be a red light emitting layer, but the present invention is not limited thereto and the first light emitting layer **550a** may be a green or blue light emitting layer.

Next, as shown in FIG. 10G, a second hole injection layer **530b**, a second hole transport layer **540b**, a second light

emitting layer **550b**, a second electron transport layer **560b**, and a second common electrode **580b**, which are formed of a thin film for a second hole injection layer, a thin film for a second hole transport layer, a second organic film, a thin film for a second electron transport layer, and a second conductive film, respectively, are formed on the substrate **510** through a second photo process which is substantially the same as the first photo process as mentioned above.

Here, the second conductive film may be made of a reflective conductive material including calcium (Ca), barium (Ba), magnesium (Mg), aluminum (Al), silver (Ag), or the like, or a transparent conductive material such as ITO, IZO, or the like.

Here, for example, the second light emitting layer **550b** may be a green light emitting layer. However, the present invention is not limited thereto and when the first light emitting layer **550a** is a red light emitting layer, the second light emitting layer **550b** may be a blue light emitting layer, other than a green light emitting layer.

Thereafter, as shown in FIG. 10H, a third hole injection layer **530c**, a third hole transport layer **540c**, a third light emitting layer **550c**, a third electron transport layer **560c**, and a third common electrode **580c**, which are formed of a thin film for a third hole injection layer, a thin film for a third hole transport layer, a third organic film, a thin film for a third electron transport layer, and a third conductive film, respectively, are formed on the substrate **510** through a third photo process which is substantially the same as the first and second photo processes as mentioned above.

Here, the third conductive film may be made of a reflective conductive material including calcium (Ca), barium (Ba), magnesium (Mg), aluminum (Al), silver (Ag), or the like, or a transparent conductive material such as ITO, IZO, or the like.

Here, for example, when the first light emitting layer **550a** is a red light emitting layer and the second light emitting layer **550b** is a green light emitting layer, the third light emitting layer **550c** may be a blue light emitting layer. Also, when the first light emitting layer **550a** is a red light emitting layer and the second light emitting layer **550b** is a blue light emitting layer, the third light emitting layer **550c** may be a green light emitting layer. However, the present invention is not limited thereto and the first light emitting layer **550a**, the second light emitting layer **550b**, and the third light emitting layer **550c** may be configured as red, green, and blue light emitting layers irrespective of order.

In the OLED display device configured as described above, the first gate electrode connected to the gate line and the first source electrode and the first drain electrode connected to the data line may constitute a first switching thin film transistor (TFT) along with the first active layer. Also, the second gate electrode connected to the first drain electrode, the second source electrode connected to the driving voltage line, and the second drain electrode connected to the pixel electrode **520** may constitute a driving TFT along with the second active layer.

Also, the pixel electrode **520**, the light emitting layers **550a**, **550b**, and **550c**, and the common electrodes **580a**, **580b**, and **580c** may constitute an OLED, and the mutually overlapping storage electrode and driving voltage line may constitute a storage capacitor.

Here, in the OLED display device according to the fifth embodiment of the present invention, the organic compound layer and the common electrodes are patterned at intervals between neighboring pixels, but the present invention is not limited thereto.

FIGS. 11A through 11H are sequential sectional views illustrating a method for fabricating an OLED display device according to a sixth embodiment of the present invention, in which a method for fabricating an OLED diode with respect to some pixels is taken as an example.

In this case, the OLED display device according to a sixth embodiment of the present invention has the same configuration as that of the fifth embodiment of the present invention, except that the organic compound layer and the common electrodes are patterned to be in contact with each other between neighboring pixels.

Although not shown, in an OLED display device according to the sixth embodiment of the present invention, a gate line including a first gate electrode and a storage electrode including a second gate electrode may be formed on a substrate **610** made of an insulating material such as transparent glass, plastic, or the like.

A gate insulating layer made of silicon nitride (SiNx), silicon oxide (SiO₂), or the like, may be formed on the gate line including the first gate electrode and the storage electrode including the second electrode.

A first active layer and a second active layer, made of semiconductor, may be formed on the gate insulating layer. The first active layer and the second active layer may be positioned on the first gate electrode and the second gate electrode, respectively.

A data line, a driving voltage line, a first source/drain electrode, and a second source/drain electrode may be formed on an upper portion of the first active layer and the second active layer.

A predetermined passivation layer may be formed on the substrate **610** on which the data line, the driving voltage line, the first source/drain electrode, and the second source/drain electrode have been formed.

As shown in FIG. 11A, a pixel electrode **620** and a connecting electrode (not shown) may be formed on the substrate **610** with the passivation film formed thereon. The pixel electrode **620** and the connecting electrode may be made of a transparent conductive material such as indium tin oxide (ITO) or a reflective conductive material such as aluminum, silver, or an alloy thereof.

The pixel electrode **620** as an anode may be electrically connected to the second drain electrode through a second contact hole, and the connecting electrode may electrically connect the first drain electrode and the second gate electrode through a first contact hole and a third contact hole.

A partition (not shown) may be formed on the substrate **610** with the pixel electrode **620** formed thereon. Here, the partition may encompass the edges of the pixel electrode **620**, like a bank, to define an opening, and may be made of an organic insulating material or an inorganic insulating material.

An organic compound layer may be formed on the substrate **610**.

Here, the organic compound layer may have a multilayer structure including an auxiliary layer in order to enhance luminous efficiency of a light emitting layer that emits light, besides the light emitting layer. The auxiliary layer may include an electron transport layer and a hole transport layer for balancing electrons and holes and an electron injection layer and a hole injection layer for strengthening injection of electrons and holes.

Namely, as shown in FIG. 11B, a thin film **631** for a first hole injection layer, a thin film **641** for a first hole transport layer, a first organic film **651**, a thin film **661** for a first electron transport layer, and a first conductive film **681** are

sequentially deposited on the substrate **610** with the pixel electrode **620** formed thereon.

Here, the thin film **661** for a first electron transport layer may include a thin film for a first electron injection layer, and the first conductive film **681** may be made of a reflective conductive material including calcium (Ca), barium (Ba), magnesium (Mg), aluminum (Al), silver (Ag), or the like, or a transparent conductive material such as ITO, IZO, or the like.

Thereafter, as shown in FIG. 11C, a photosensitive resin is coated on the entire surface of the substrate **610**, on which the thin film **631** for a first hole injection layer, the thin film **641** for a first hole transport layer, the first organic film **651**, the thin film **661** for a first electron transport layer, and the first conductive film **681** have been deposited, to form a first photosensitive resin layer **691**.

Thereafter, UV rays are selectively irradiated to the first photosensitive resin layer **691** through a certain mask M.

Thereafter, when the first photosensitive resin layer **691** exposed through the mask M is developed, a first photosensitive resin pattern **690a** made of the photosensitive resin remains only at a position where a first light emitting layer is to be formed as shown in FIG. 11D.

Here, the first photosensitive resin pattern **690a** may be patterned such that the organic compound layer and a common electrode are patterned to be in contact with each other between neighboring pixels.

Thereafter, as shown in FIG. 11E, when a partial region of first conductive film formed under the first photosensitive resin pattern **690a** is selectively etched by using the first photosensitive resin pattern **690a** as a mask, a first common electrode **680a** formed of the first conductive film is formed at a position where the first light emitting layer is to be formed.

Here, the etching may include wet etching as well as dry etching.

Thereafter, as shown in FIG. 11F, a remnant of the first photosensitive resin pattern is removed through ashing, stripping, or the like, and here, as partial regions of the thin film for a first hole injection layer, the thin film for a first hole transport layer, the first organic film, and the thin film for a first electron transport layer exposed thereunder are selectively removed by using the first common electrode **680a** as a mask, a first hole injection layer **630a**, a first hole transport layer **640a**, a first light emitting layer **650a**, and a first electron transport layer **660a**, which are formed of the thin film for a first hole injection layer, the thin film for a first hole transport layer, the first organic film, and the thin film for a first electron transport layer, respectively, are formed (a first photo process).

In this manner, since the first common electrode **680a** is positioned as a barrier layer on an upper portion of the organic compound layer, namely, on the first electron transport layer **660a**, the organic compound layer, in particular, the first electron transport layer **660a**, can be prevented from being degraded during the photo process, thus preventing a degradation of the device.

Here, the first light emitting layer **650a** may be a red light emitting layer, but the present invention is not limited thereto and the first light emitting layer **650a** may be a green or blue light emitting layer.

Next, as shown in FIG. 11G, a second hole injection layer **630b**, a second hole transport layer **640b**, a second light emitting layer **650b**, a second electron transport layer **660b**, and a second common electrode **680b**, which are formed of a thin film for a second hole injection layer, a thin film for a second hole transport layer, a second organic film, a thin

film for a second electron transport layer, and a second conductive film, respectively, are formed on the substrate **610** through a second photo process which is substantially the same as the first photo process as mentioned above.

Here, the second conductive film may be made of a reflective conductive material including calcium (Ca), barium (Ba), magnesium (Mg), aluminum (Al), silver (Ag), or the like, or a transparent conductive material such as ITO, IZO, or the like.

Here, for example, the second light emitting layer **650b** may be a green light emitting layer. However, the present invention is not limited thereto and when the first light emitting layer **650a** is a red light emitting layer, the second light emitting layer **650b** may be a blue light emitting layer, other than a green light emitting layer.

Thereafter, as shown in FIG. 11H, a third hole injection layer **630c**, a third hole transport layer **640c**, a third light emitting layer **650c**, a third electron transport layer **660c**, and a third common electrode **680c**, which are formed of a thin film for a third hole injection layer, a thin film for a third hole transport layer, a third organic film, a thin film for a third electron transport layer, and a third conductive film, respectively, are formed on the substrate **610** through a third photo process which is substantially the same as the first and second photo processes as mentioned above.

Here, the third conductive film may be made of a reflective conductive material including calcium (Ca), barium (Ba), magnesium (Mg), aluminum (Al), silver (Ag), or the like, or a transparent conductive material such as ITO, IZO, or the like.

Here, for example, when the first light emitting layer **650a** is a red light emitting layer and the second light emitting layer **650b** is a green light emitting layer, the third light emitting layer **650c** may be a blue light emitting layer. Also, when the first light emitting layer **650a** is a red light emitting layer and the second light emitting layer **650b** is a blue light emitting layer, the third light emitting layer **650c** may be a green light emitting layer. However, the present invention is not limited thereto and the first light emitting layer **650a**, the second light emitting layer **650b**, and the third light emitting layer **650c** may be configured as red, green, and blue light emitting layers irrespective of order.

In the OLED display device configured as described above, the first gate electrode connected to the gate line and the first source electrode and the first drain electrode connected to the data line may constitute a first switching thin film transistor (TFT) along with the first active layer. Also, the second gate electrode connected to the first drain electrode, the second source electrode connected to the driving voltage line, and the second drain electrode connected to the pixel electrode **620** may constitute a driving TFT along with the second active layer.

Also, the pixel electrode **620**, the light emitting layers **650a**, **650b**, and **650c**, and the common electrodes **680a**, **680b**, and **680c** may constitute an OLED, and the mutually overlapping storage electrode and driving voltage line may constitute a storage capacitor.

As the present invention may be embodied in several forms without departing from the characteristics thereof, it should also be understood that the above-described embodiments are not limited by any of the details of the foregoing description, unless otherwise specified, but rather should be construed broadly within its scope as defined in the

appended claims, and therefore all changes and modifications that fall within the metes and bounds of the claims, or equivalents of such metes and bounds are therefore intended to be embraced by the appended claims.

What is claimed is:

1. A method for fabricating an organic light emitting diode (OLED) display device, the method comprising:

(a) forming a first electrode on a substrate;

(b) applying a photosensitive resin to the entire surface of the substrate to form a first photosensitive resin layer;

(c) selectively exposing and developing the first photosensitive resin layer to form a first photosensitive resin pattern made of the photosensitive resin at a position other than a position where a first light emitting layer is to be formed;

(d) depositing a thin film for a first hole injection layer, a thin film for a first hole transport layer, a first organic film, a thin film for a first electron transport layer, and a thin film for a first buffer layer in a state in which the first photosensitive resin pattern remains;

(e) removing the thin film for the first hole injection layer, the thin film for the first hole transport layer, the first organic film, the thin film for the first electron transport layer, and the thin film for the first buffer layer deposited on an upper portion of the first photosensitive resin pattern through a lift-off process to form the first hole injection layer, the first hole transport layer, the first light emitting layer, the first electron transport layer, and the first buffer layer, which are formed of the thin film for the first hole injection layer, the thin film for the first hole transport layer, the first organic film, the thin film for the first electron transport layer, and the thin film for the first buffer layer, respectively, on the substrate;

(f) forming a second hole injection layer, a second hole transport layer, a second light emitting layer, a second electron transport layer, and a second buffer layer through the same processes as (b) to (e);

(g) forming a third hole injection layer, a third hole transport layer, a third light emitting layer, a third electron transport layer, and a third buffer layer through the same processes as (b) to (e); and

(h) forming a second electrode on the first, second, and third buffer layers, wherein the first, second, and third buffer layers are made of a metal oxide.

2. The method of claim **1**, wherein the first, second, and third buffer layers are made of a 1-2 Group and 12-16 Group metal oxide or 3-12 Group transition metal oxide.

3. The method of claim **1**, wherein the first light emitting layer is formed of any one of red, green, and blue light emitting layers.

4. The method of claim **3**, wherein the second light emitting layer is formed of another one of the red, green, and blue light emitting layers.

5. The method of claim **4**, wherein the third light emitting layer is formed of the other remaining one of the red, green, and blue light emitting layers.

6. The method of claim **1**, wherein the second electrode includes first, second, and third patterns respectively formed on the first, second, and third buffer layers.

* * * * *

专利名称(译)	有机发光二极管显示装置及其制造方法		
公开(公告)号	US10547017	公开(公告)日	2020-01-28
申请号	US16/287312	申请日	2019-02-27
[标]申请(专利权)人(译)	乐金显示有限公司		
申请(专利权)人(译)	LG DISPLAY CO. , LTD.		
当前申请(专利权)人(译)	LG DISPLAY CO. , LTD.		
[标]发明人	KIM YOUNG MI YOON JONG GEUN HEO JOON YOUNG PARK HAN SUN DO EUI DOO LEE YEON KYEONG KIM DAE HYUN SHIM JONG SIK		
发明人	KIM, YOUNG-MI YOON, JONG-GEUN HEO, JOON-YOUNG PARK, HAN-SUN DO, EUI-DOO LEE, YEON-KYEONG KIM, DAE-HYUN SHIM, JONG-SIK		
IPC分类号	H01L51/50 H01L51/00 H01L27/32 H01L51/56 H01L51/52 H01L33/20 H01L33/62 H01L27/15		
CPC分类号	H01L51/5092 H01L51/5072 H01L27/3218 H01L51/5234 H01L51/5056 H01L51/5088 H01L51/0002 H01L51/56 H01L51/0018 H01L51/0016 H01L51/5012 H01L27/3211 H01L27/153 H01L33/62 H01L33/20		
审查员(译)	NGUYEN , THINH T		
优先权	1020110095959 2011-09-22 KR 1020120101196 2012-09-12 KR 15/215339 2018-05-01 US		
其他公开文献	US20190198792A1		
外部链接	Espacenet		

摘要(译)

在有机发光二极管 (OLED) 显示装置及其制造方法中, 通过光刻工艺对OLED像素进行构图, 因此可以进行大面积构图并且可以获得精细的间距, 并且可以形成有机化合物层。通过在有机化合物层的上部上形成金属氧化物的缓冲层或通过使用阴极作为掩模来对有机化合物层进行图案化来保护器件, 从而提高了器件效率。另外, 在红色, 绿色和蓝色像素中, 通过剥离工艺对两个像素进行构图, 并且将剩余的另一个像素沉积而无需构图, 从而可以简化工艺并提高效率。

